

# LEVEL

## Bypass Level Indicators



**switch**



**measure**



**control**

# Index

<b>Introduction and General Information</b>	Function Principle, Materials, Indication Flags .....	3
	Indication Rail Assembly, Floats .....	4
	Mounting Brackets, Heat Tracing Isolation, Weather Protection .....	5
	Limit Values .....	6
	Transmitters .....	7
<b>Overview</b>	Product Overview .....	8 - 11
<b>Mini-Bypass Level Indicators made of Stainless Steel</b>	Type BNA-S21 / -S22 .....	12
<b>Bypass Level Indicators made of Stainless Steel</b>	Type BNA-S31 / -S32 .....	13
	Type BNA-S35 / -S36 .....	14
	Type BNA-S41 / -S42 .....	15
	Type BNA-S45 / -S46 .....	16
	Type BNA-S51 / -S52 .....	17
<b>Bypass Level Indicators for Top Tank Mounting</b>	Type BNA-U101 / -U102 .....	18
	Type BNA-U301 / -U401 / -U701 .....	19
<b>Bypass Level Indicators made of Plastics</b>	Type BNA-K301 / -K401 / -K701 .....	20
	Type BNA-K302.0 / -K402.0 / -K702.0 .....	20
	Type BNA-K302.1 / -K402.1 / -K702.1 .....	21
	Type BNA-K303 / -K403 / -K703 .....	21
<b>Accessories</b>	Limit Switches Type GK01/GK01L/GK02/GK HT1 .....	22
	Floats .....	23
	Transmitters XM, XMi .....	24
	Transmitters XT, XTi .....	25
	Trip Amplifier UAS3 .....	26
	Scale, Isolation, Heating .....	28
	Order Numbers .....	29 - 33
	Product Overview, Fax Order Form .....	34

# Introduction

## Function Principle

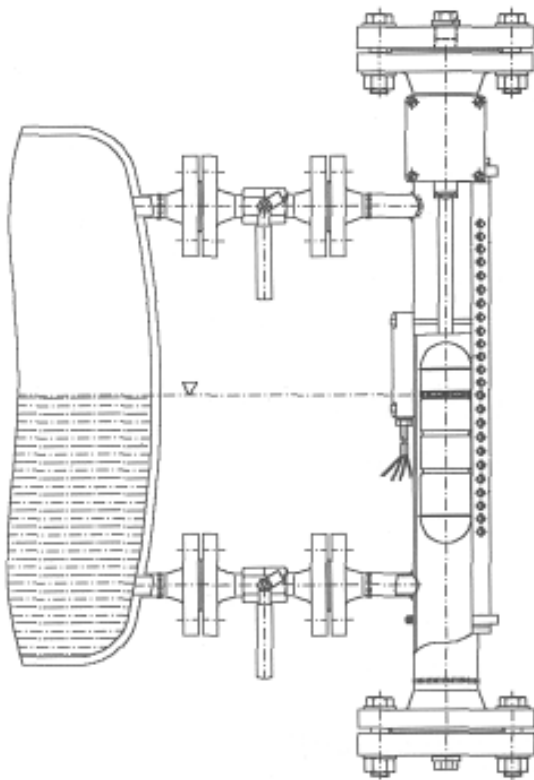

The **Barksdale** Bypass Level Indication System combines the convenience of a sight glass and the strength of a Stainless Steel tube, with the only difference; there is no glass to break or seals to leak. Colourless clean, or even dirt contaminated liquids are indicated by a row of red / white coloured rotating flags and can be seen from great distances.

The bypass tube is connected by side / side, or top and bottom connections with the tank. A magnetic float inside the bypass tube rides on the same level as in the tank and operates the coloured flags, the limit switches and / or the optional level transmitter on the outside of the tube.

The special permanent magnet design provides a 360 degree magnetic flux field. This allows the indication rail, the limit switches and continuous level sensor to be located anywhere around the bypass tube.

The Bypass Level Indication System is available in a variety of metals and plastics.

Except for the tank top version, we can serve many applications up to standard 64 bar and 350 °C.

Depending on process requirements we offer many options such as: special floats, calibrated scales, trace heating, isolations, drain valves, various international construction standards, special tests and approvals.

Bypass level tubes with total length > 3 meters can cause higher packing, transport and installation costs than short sections. We therefore offer split versions which can be flanged together on site during installation.

Please contact us for details.

**Attention:** The indication rail will be interrupted for 30 to 50 mm at the split. In this gap neither indication nor limit switches are possible.

## Materials

Bypass tube, flanges and floats are as standard available in: Stainless Steel 316 Ti / 1.4571, Titanium, PVC, PVDF, or Polypropylene.

Optional metals and cladding, Teflon lining, chemical metalising, and coatings are available on demand.

## Indication Flags

The rotary flags are large in size and brilliant in colour. These square section rotary flags are magnetically interlocked, designed to maintain their relative position even when subject to significant vibration. They rotate from white to red when the magnet quipped float rises with the liquid level in the bypass tube and clearly indicate the level which can be seen from over thirty meters away.

In one meter indication there are 80 flags, corresponding to an accuracy of 1,25% for one meter, or 0,6% for two meter indication length. Aluminum flags are painted red and aluminum and can be subjected to 320 °C, the polycarbonate flags can be exposed to 150 °C medium, equals 120 °C ambient temperature.

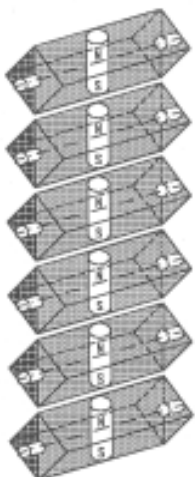

# Introduction

## Indication Rail Assembly

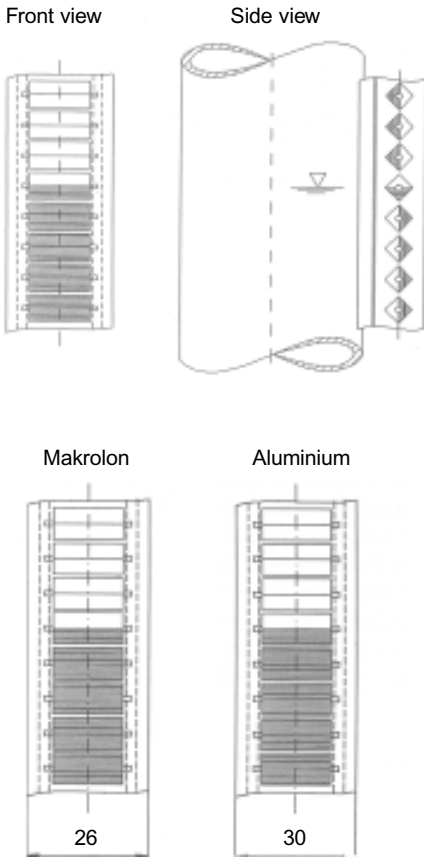

Indication rail assemblies are available in polycarbonate (Makrolon) and anodised aluminium for high Temperatures. The polycarbonate assemblies are 26 mm wide, clear, virtually resistant against UV, chemically polluted atmospheres and impacts and offer 180° visibility. The extruded aluminum indication rails are anodised, 30 mm wide and have glass panes to protect the flags. They can be subjected to 320 °C ambient or 350 °C medium temperatures.

The indication rail assemblies are attached to the outside of the bypass tube with stainless steel clamps and therefore can easily be positioned in the direction needed for optimal reading (not possible with the double wall / tube design).

The end caps on the rails protect the flags against dirt or dust, however when rain or freezing conditions can be expected we recommend an additional shrink tubing. Please see also page 6.

Flags which are in the wrong position due to external magnetic influences will automatically return to the right position by the flux field of the float on the next passing by.

## Floats

The floats are fabricated in various standard versions: stainless steel, Titanium, PVC, PP, or PVDF (Kynar). Please see page 23. The stainless steel versions in 1.4571 (316Ti) can be used up to 150 °C medium temperatures, the Titanium up to 320 °C.

In the metal floats the top extends 50 mm above the magnet. Depending on the specific gravity  $\rho$  (equals density) of the fluid the float raises or lowers its floating position and therefore influences the indication accuracy.

The type VA50/15 and TT50/15 floats are designed to simply match the indication with the liquid level in the bypass tube by adding weight in the float for fluids with higher densities.

These floats are also used for interface measurement between two liquids; for example oil and water; the float will sink through the oil and floats on the water.

Interface application require a minimum specific gravity difference of 0,2.

For pressures over 40 bar we have vented floats VA50/20 and TT50/20 which have a vent tube for equalising the inside and outside pressure of the float. This vent tube automatically removes with each small pressure drop condensate from the inside of the float back into the bypass tube.

These vented floats should not be exposed to pressure shocks; it is important that the system will be brought up to pressure slowly.

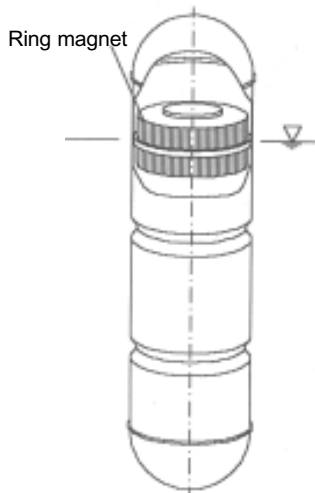

# Introduction

## Mounting Brackets

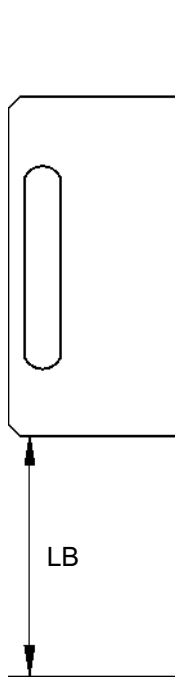

In the standard version we supply all bypass indication systems with top and bottom process connections with mounting brackets; the 60 mm  $\varnothing$  metal versions with welded-on bracket(s), the others in engineered plastics (K) and the S21/ S22 version have clamped-on bracket(s).

When not specified otherwise the dimension LB1 is 300 mm for all units with a total length (L0) > 1000 mm.

For L0 up to 2000 mm LB1 is 300 mm and LB2 = L0 – 400 mm.

For L0 over 3000 mm there is a bracket in the middle (LBm)

between LB1 and LB2. LBm = LB1 – LB2 .

When the bypass tube is a split version there will be a bracket 200 mm under the “split” flange facing and another bracket 100 mm above.

All LB dimensions are measured from the bottom of the bracket.

When other dimensions are required they must be listed explicitly in the order.

## Heat Tracing

To prevent the cooling or freezing of liquids in the bypass tube we offer an electric heat trace system or a double tube design to be used with steam or water. This double tube design can be used with chilled water when cooling is needed.

It is recommended to order this option with an isolation or plan to have these isolated together with the rest of the installation.

## Isolation

For personal protection we offer a woven glass isolation (–40 °C...400 °C) around the tube, a rubber foam type isolation (–40 °C...105 °C) for low temperatures, and a calcium silicate and aluminium isolation to save energy with high temperatures up to 400 °C.

## Weather Protection

For outdoor or applications where moisture or dust can be expected we recommend the use of our protective shrink tubing for the indication rail.

This transparent Polyolefin shrink tubing offers also a good resistance against oil, vapours and gases in the chemical industry and reduces freezing of the surface and ice build-up.

Cleaning with water or steam is easy; the use of solvents is not recommended. Temperature limits: –55 °C...135 °C.

## Introduction

**Limit Switches** Barksdale offers a line of various Limit Switches:

- GK 01 (Standard)
- GK 01L with two LED's indicating switch status
- GK 02 in EEx d
- GK HT1 (high temperature version).

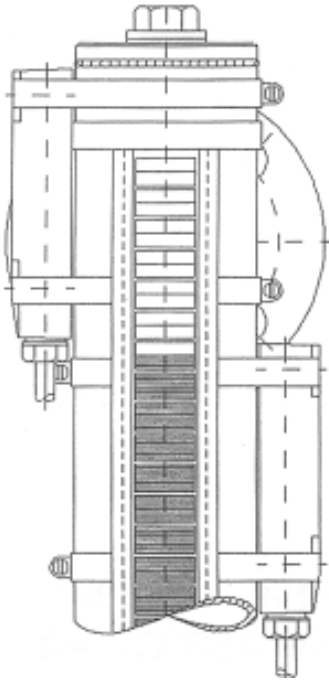

As the float rises with the liquid level the magnet system will switch-over the contact. This contact status will remain until the float passes again and the switch status returns to it's original position.

Besides the GK HT1 which has a micro switch, all other Limit Switches have bi-stable reed contacts.

The GK 01L has a red and a green LED which indicate the switch over status of the contact whenever the float passes.

The Limit Switches are designed for quick and easy installation; only a screw driver is needed to tighten the stainless steel clamps. They can be mounted in any position around the bypass tube without influencing each other.

When frequent changing process requirements make a permanent contact position difficult to handle we recommend to order our XT level transmitters and UAS 3 trip amplifiers, which enables set point changes by touching a key pad.

## Introduction

### Continuous Level Indicating Transmitters (TLI)

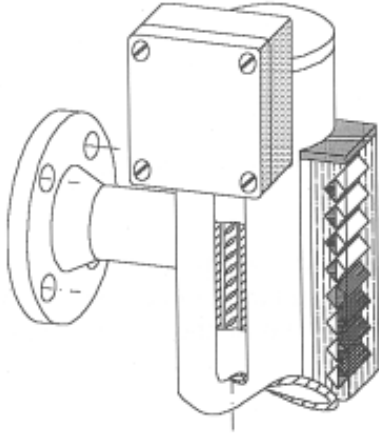

All Bypass Level Indicators are available with a strap-on transmitter with continuous (resistance) electrical output or as Level Transmitter with integrated signal conditioner and a two-wire 4...20 mA output.

The measuring principle is a static chain of magnetically activated reed switches with resistors arranged inside a vertical SS tube at 12,7 mm intervals.

The flux field transmitted by the float causes reed switches to operate in a „2-3-2 at a time“ sequence, rendering an effective reading of 6,35 mm accuracy regardless of the length of the chain and provide a reed switch and signal redundancy.

Intrinsically safe versions XMi and XTi are available for hazardous areas, when needed, there is also a digital version with Hart protocol configuration.

For interface level measurement the output signal can easily be inverted (20...4 mA).

### Special Designs

**This catalog contains only our standard program.**

**There are many more versions available, please contact us. We are happy to assist you.**

# Overview

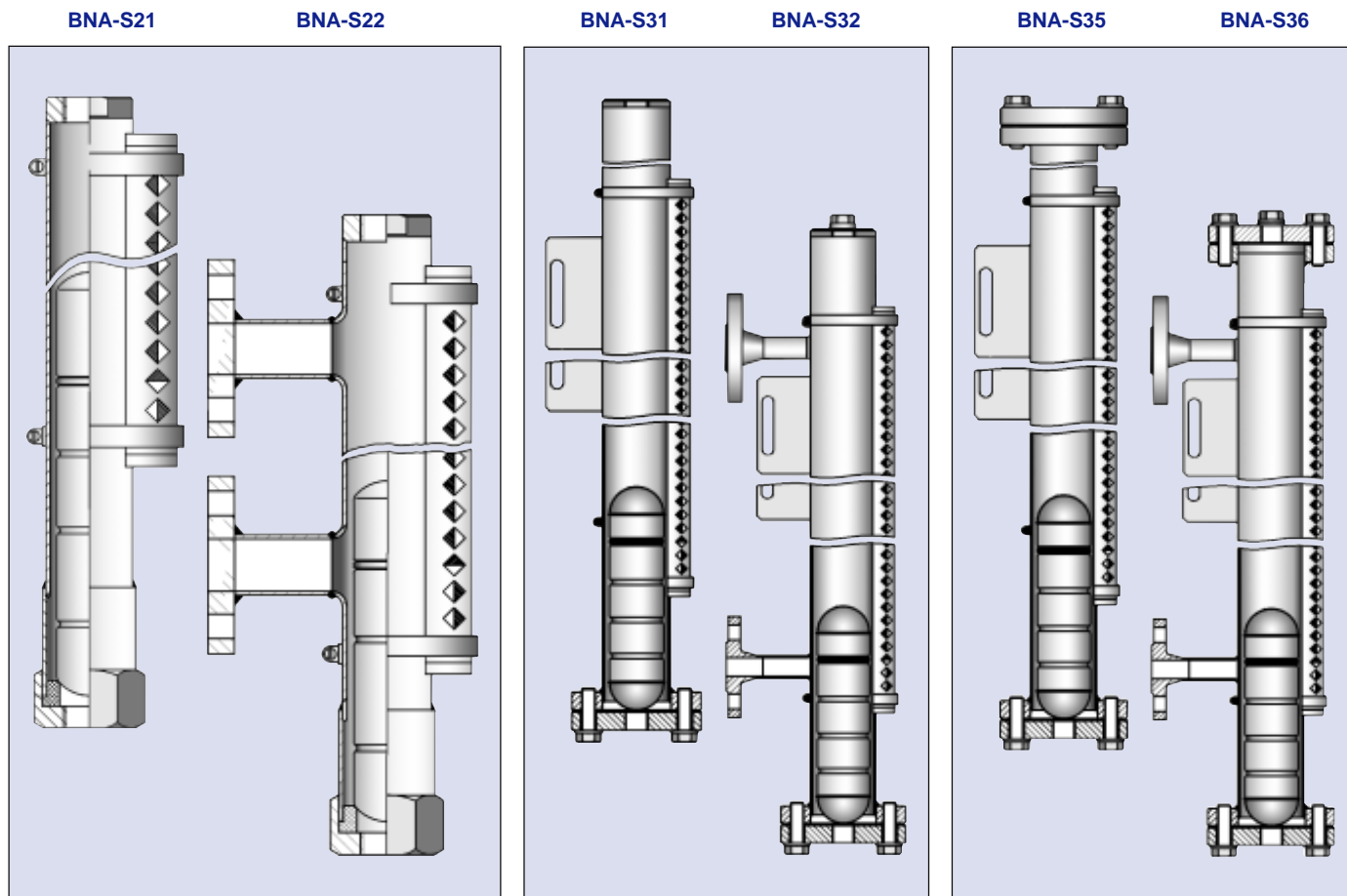

Type	BNA-S21 BNA-S22	BNA-S31 BNA-S32	BNA-S35 BNA-S36
<b>Measuring Ranges</b>	LM max. 3000 mm in one piece, max. LM in split sections on request	LM max. 6000 mm in one piece, max. LM in split sections on request	LM max. 6000 mm one piece, max. LM in split sections on request
<b>Indication Rail Assembly</b>	Makrolon (Polycarbonate), with red/white square flags	Makrolon (Polycarbonate), with red/white square flags	Makrolon (Polycarbonate), with red/white square flags
<b>Process Connection (without Adaptor)</b>	BNA-S21: top and bottom G 1/2 BNA-S22: side mounted	BNA-S31: top and bottom G 1/2 BNA-S32: side mounted	BNA-S35: top and bottom G 1/2 BNA-S36: side mounted
<b>Stem</b>	Stainl. St. 1. 4571 (SS 316 Ti) PN 25, Diameter 40 x 1 mm	Stainl. St. 1. 4571 (SS 316 Ti) PN 16, Diameter 60,3 x 2 mm	Stainl. St. 1.4571 (SS 316 Ti) PN 16, Diameter 60, 3 x 2 mm
<b>Float</b>	Standard: VA 30/02, (SS 316Ti) 1.4571, max. 25 bar and 150 °C, min. Density: 0,85 g/cm <sup>3</sup>	Standard PN 25: VA 50/10 in 1.4571, min. Density: 0,62 g/cm <sup>3</sup> , max. Temperature: 150 °C	Standard PN 25: VA 50/10 in 1. 4571min. Density: 0,62 g/cm <sup>3</sup> , max. Temperature: 150 °C
<b>Max. Pressure in bar</b>	25 bar	16 bar	16 bar
<b>Max. Temperature</b>	150 °C	150 °C	150 °C
<b>Options</b>	Titanium- / Buna-N Float	Alu-Indication Rail, Titanium-Float, Special Connections	Alu-Indication Rail, Titanium-Float, Special Connections
<b>Approvals</b>	Shipbuilding Approval	Shipbuilding Approval	Shipbuilding Approval

09 / 02 BNA-ENG 02/1

Barksdale Bypass Level Indicators

Specifications are subject to changes without notice.

# Overview

09 / 02 BNA-ENG 02/1

Barksdale Bypass Level Indicators

Specifications are subject to changes without notice.

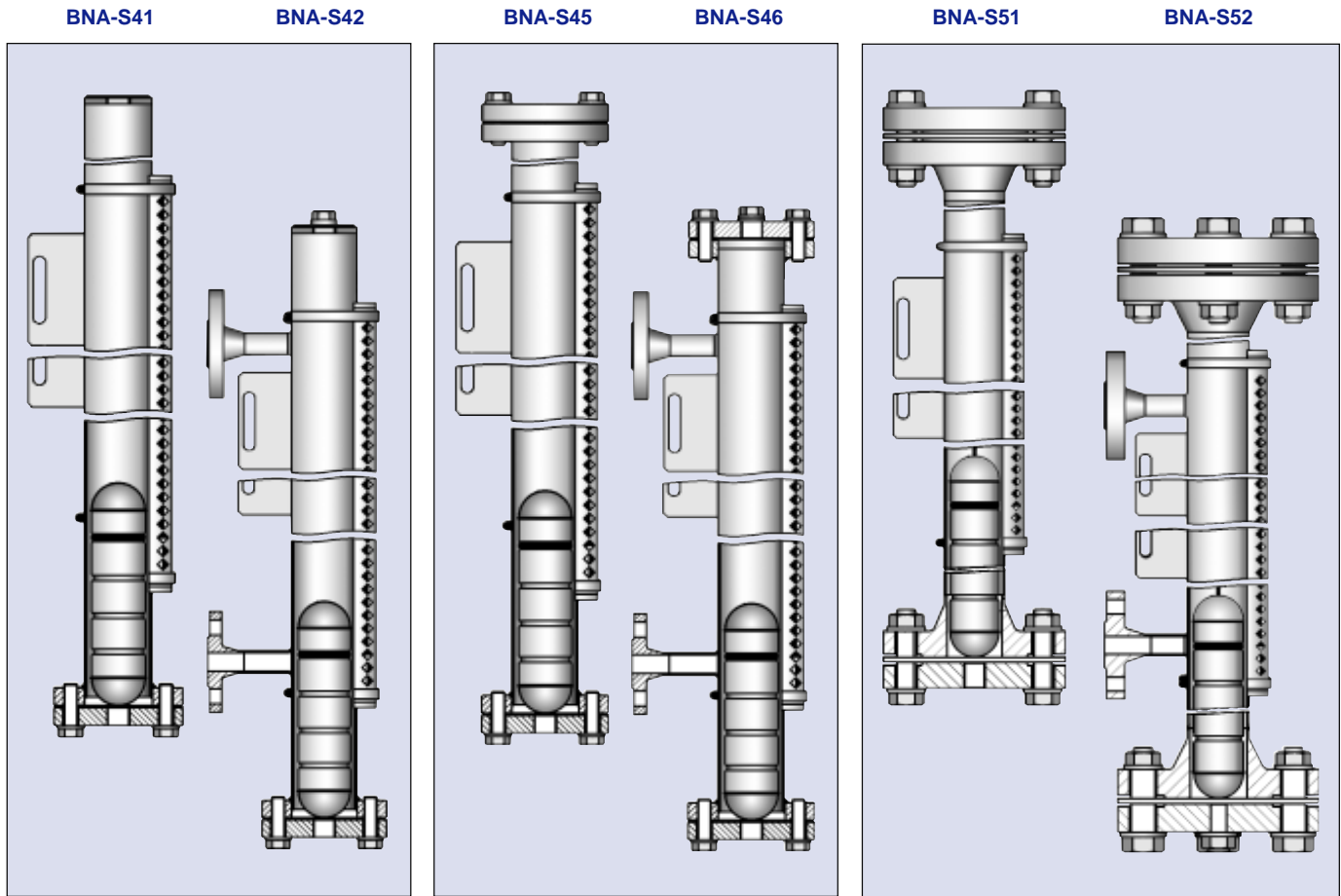

Type	BNA-S41 BNA-S42	BNA-S45 BNA-S46	BNA-S51 BNA-S52
<b>Measuring Ranges</b>	LM max. 6000 mm one piece, split sections also longer, max. LM on request	LM max. 6000 mm one piece, split sections also longer, max. LM on request	LM max. 6000 mm one piece, split sections also longer, max. LM on request
<b>Indication Rail Assembly</b>	Makrolon (Polycarbonate), with red/white square flags	Makrolon (Polycarbonate), with red/white square flags	Makrolon (Polycarbonate), with red/white square flags
<b>Process Connection (without Adaptor)</b>	BNA-S41: top and bottom G 1/2 BNA-S42: side mounted	BNA-S45: top and bottom G 1/2 BNA-S46: side mounted	BNA-S51: top and bottom G 1/2 BNA-S52: side mounted
<b>Stem</b>	Stainl. St. 1.4571 (SS 316 Ti) PN 40, Diameter 60,3 x 2 mm	Stainl. St. 1.4571 (SS 316 Ti) PN 40, Diameter 60,3 x 2 mm	Stainl. St. 1.4571 (SS 316 Ti) PN 64, Diameter 60,3 x 2 mm
<b>Float</b>	Standard PN 40: TT 50/10 in Titan, min. Density: 0,56 g/cm <sup>3</sup> , max. Temperature: 320 °C	Standard PN 40: TT 50/10 in Titan, min. Density: 0,56 g/cm <sup>3</sup> , max. Temperature: 320 °C	Standard: VA 50/20-VAE (vented) in 1.4571, min. Density: 0,65 g/cm <sup>3</sup> , max. Temperature: 150 °C
<b>Max. Pressure in bar</b>	40 bar	40 bar	64 bar
<b>Max. Temperature</b>	320 °C	320 °C	150 °C
<b>Options</b>	Alu-Indication Rail, Titanium-Float, Special Connections	Alu-Indication Rail, Titanium-Float, Special Connections	Alu-Indication Rail, Titanium-Float, Special Connections
<b>Approvals</b>	Shipbuilding Approval	Shipbuilding Approval	Shipbuilding Approval

# Overview

**BNA-U101**

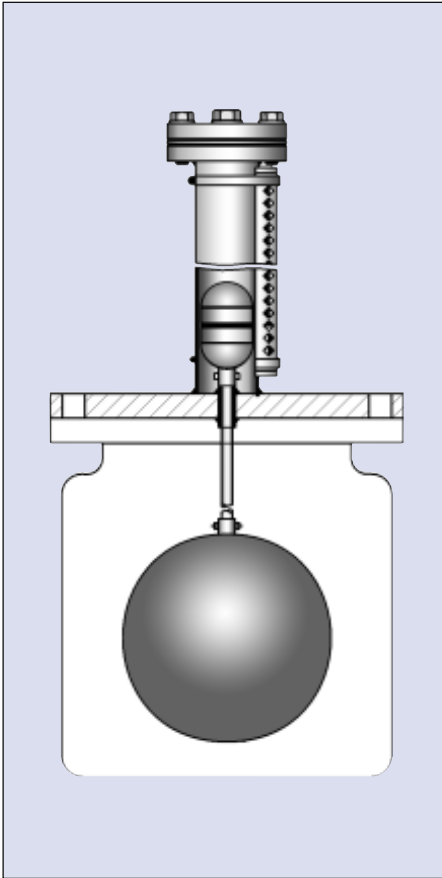

**BNA-U102**

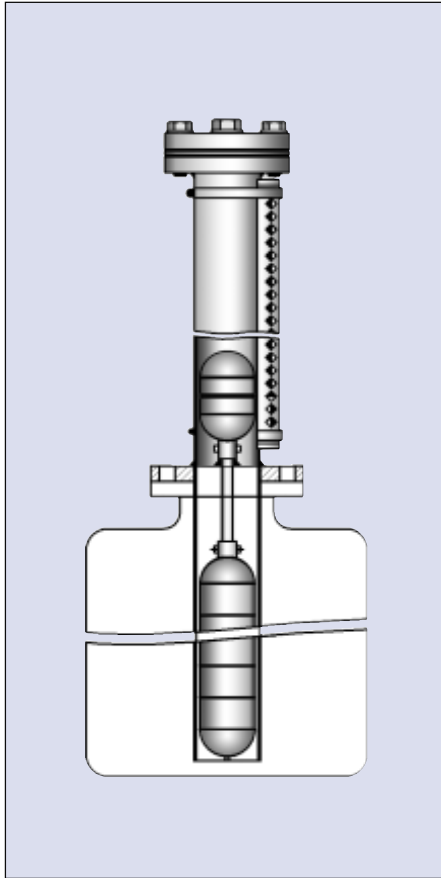

**BNA-U301 BNA-U401 BNA-U701**

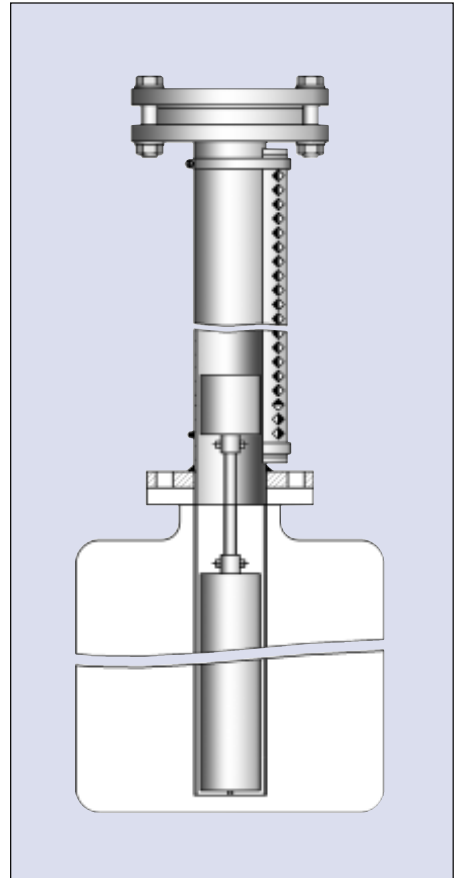

Type	BNA-U101	BNA-U102	BNA-U301 BNA-U401 BNA-U701
<b>Measuring Ranges</b>	Depends on the buoyancy of the float (which again depends on the density of the medium (g)), max. LM on request	Depends on the buoyancy of the float (which again depends on the density of the medium (g)), max. LM on request	Depends on the buoyancy of the float (which again depends on the density of the medium (g))
<b>Indication Rail Assembly</b>	Makrolon (Polycarbonate), with red/white square flags	Makrolon (Polycarbonate), with red/white square flags	Makrolon (Polycarbonate), with red/white square flags
<b>Process Connection (without Adaptor)</b>	VA Flange DIN 2527 DN 200 / PN 16 LM max. 6000 mm, 5300 mm /	VA Flange DIN 2527 DN 65 / PN 16 LM max. 4500 mm /	Flange DN 65
<b>Stem</b>	Stainl. St. 1. 4571 (SS 316 Ti) PN 64, Diameter 60, 3 x 2 mm	Stainl. St. 1. 4571 (SS 316 Ti) PN 64, Diameter 60, 3 x 2 mm	Diameter 63, 3 x 2 mm
<b>Float</b>	VA 200 with VA tube 12 x 1 min. density = 0,6 g/cm <sup>3</sup>	VA 50-400 mit ABS Rohr min. density = 0,6 g/cm <sup>3</sup>	PVC 300, LM 1000 mm, min. dens. 0,7 g/cm <sup>3</sup> PVC 300, LM 2000 mm, min. dens. 0,8 g/cm <sup>3</sup> PVC 400, LM 2000 mm, min. dens. 0,67 g/cm <sup>3</sup> PP 300, LM 4000 mm, min. dens. 0,8 g/cm <sup>3</sup> PP 400, LM 4000 mm, min. dens. 0,67 g/cm <sup>3</sup>
<b>Max. Pressure in bar</b>	16	16	BNA-U301: 2,5 / BNA-U401: 6 BNA-U701: 2,5
<b>Max. Temperature</b>	150 °C	150 °C	BNA-U301: 60 °C / BNA-U401: 140 °C BNA-U701: 80 °C
<b>Options</b>	Alu-Indication Rail, Titanium-Float	Float, Connections	Float, Connections
<b>Approvals</b>	---	---	---

09 / 02 BNA-ENG 02/1

Barksdale Bypass Level Indicators

Specifications are subject to changes without notice.

# Overview

BNA-K301 BNA-K401 BNA-K701

BNA-K302.0 BNA-K402.0 BNA-K702.0

BNA-K302.1 /  
-K402.1 / -K702.1

BNA-K303 /  
-K403 / BNA-K703

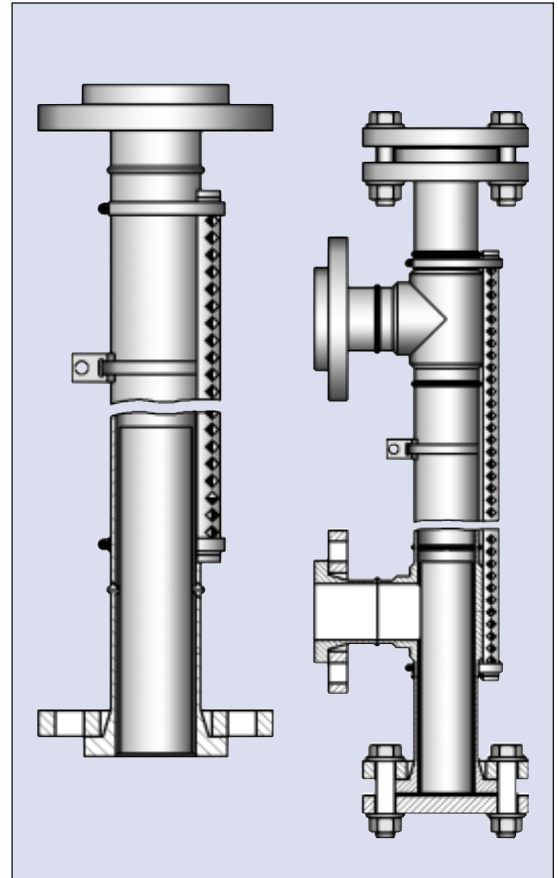
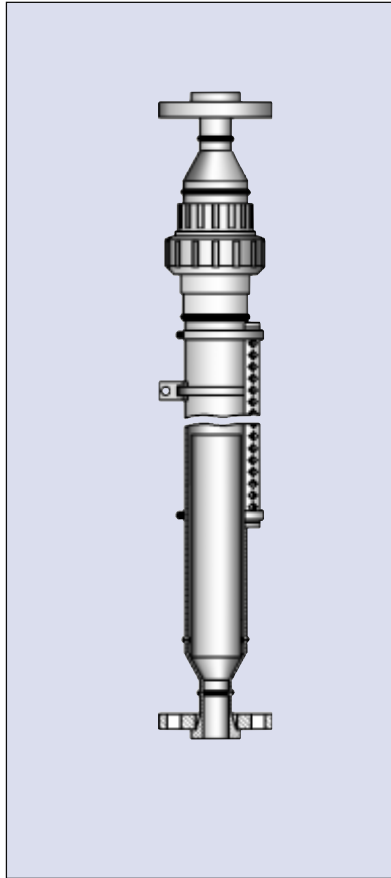
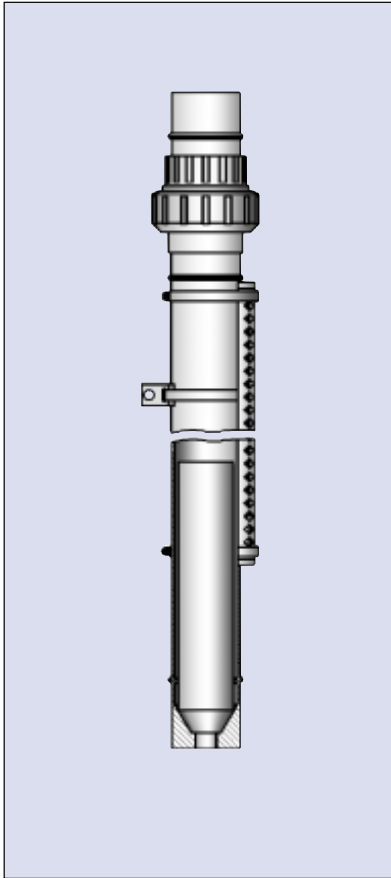

09 / 02 BNA-ENG 02/1

Barksdale Bypass Level Indicators

Specifications are subject to changes without notice.

Type	BNA-K301 BNA-K401 BNA-K701	BNA-K302.0 BNA-K402.0 BNA-K702.0	BNA-K302.1 BNA-K402.1 BNA-K702.1	BNA-K303* BNA-K403* BNA-K703*
Measuring Ranges	LM max. 3000 mm one piece, split sections on request	LM max. 3000 mm one piece, split sections on request	LM max. 3000 mm one piece, split sections on request	LM max. 3000 mm one piece, split sections on request
Indication Rail Assembly	Makrolon (Polycarbonate), with red/white square flags	Makrolon (Polycarbonate), with red/white square flags	Makrolon (Polycarbonate), with red/white square flags	Makrolon (Polycarbonate), with red/white square flags
Process Connection (without Adaptor)	with Thread	with Flanges DN 15 to DN 32	Lap joint flanges with stub ends at top DIN 8063/PN10, top + bottom DN 50 * side mounted DN 15 to DN 50	
Stem	Diameter 63,3 x 3 mm	Diameter 63,3 x 3 mm	Diameter 63 x 3 mm	
Float	PVC 50/10, min. density 0,54 g/cm <sup>3</sup> PVDF 50/10, min. density 0,66 g/cm <sup>3</sup> PP 50/10, min. density 0,45 g/cm <sup>3</sup>	PVC 50/10, min. density 0,54 g/cm <sup>3</sup> PVDF 50/10, min. density 0,66 g/cm <sup>3</sup> PP 50/10, min. density 0,45 g/cm <sup>3</sup>	PVC 50/10, min. density 0,54 g/cm <sup>3</sup> PVDF 50/10, min. density 0,66 g/cm <sup>3</sup> PP 50/10, min. density 0,45 g/cm <sup>3</sup>	PVC 50/10, min. density 0,54 g/cm <sup>3</sup> PVDF 50/10, min. density 0,66 g/cm <sup>3</sup> PP 50/10, min. density 0,45 g/cm <sup>3</sup>
Max. Pressure in bar	BNA-K301: 2,5 / BNA-K401: 6 BNA-K701: 2,5	BNA-K302.0: 2,5 / BNA-K402.0: 6 BNA-K702.0: 2,5	BNA-K302.1: 2,5 / BNA-K402.1: 6 BNA-K702.1: 2,5	
Max. Temperature	BNA-K301: 60 °C / BNA-K401: 140 °C BNA-K701: 80 °C	BNA-K302.0: 60 °C / BNA-K402.0: 140 °C BNA-K702.0: 80 °C	BNA-K302.1: 60 °C / BNA-K402.1: 140 °C BNA-K702.1: 80 °C	
Options	Special Connections	Special Connections	Special Connections	
Approvals	---	---	---	

# BNA-S21/-S22

## BNA-S21

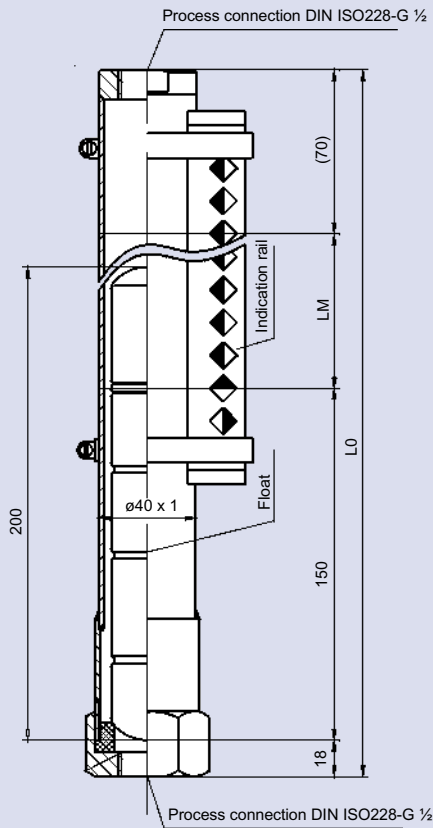

## BNA-S22

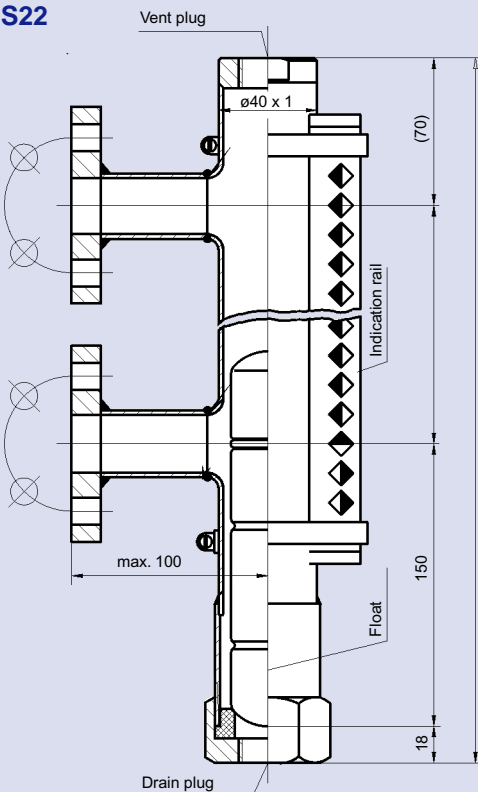

The **Mini Bypass Level Indicator** is the “light version” in the family, available with lengths up to 3000 mm, medium temperatures up to 150 °C and pressures up to 25 bar.

This “light version” is easy to handle, ideal to replace sight glasses and low in cost due to the many OEM applications.

### Technical Data

#### Standard version:

Measuring range: LM max. 3000 mm in one piece, max. LM in split sections on request

Bypass tube: Stainless Steel No. 1.4571 (SS 316 Ti) PN 25, diameter 40 x 1 mm

Proof pressure: 1,5 x max. operating pressure

Service conn.: R 1¼” with hex. nut

Process conn.: G ½ top and bottom for BNA-S21 or side connections for the BNA-S22

Indication rail: Makrolon (Polycarbonate) with red and white square flags for medium temp. up to 150 °C

Float(s): Standard: VA 30/02, (SS 316Ti) 1.4571, max 25 bar and 150 °C, min. density 0,85 g/cm<sup>3</sup>

**Type:** **BNA-S21**, G ½ top and bottom connections **BNA-S22**, side connections, Threaded R ½ , R ¾, or DIN flanges DN 15, 25 and ASA flanges DN ½”, ¾”

#### Options:

Float(s): TT 30/02, in Titanium, PN 25 min. density: 0,85 g/cm<sup>3</sup>, max. temp.: 150 °C

Buna N : BN 32/100, PN 10 min. density: 0,62 g/cm<sup>3</sup>, max. temp.: 90 °C

more floats on request

#### Accessories:

Limit switches  
Analog output  
Scale  
Isolation  
Tests / Certificates

# BNA-S31/-S32

09 / 02 BNA-ENG 02/1

Barksdale Bypass Level Indicators

Specifications are subject to changes without notice.

## BNA-S31

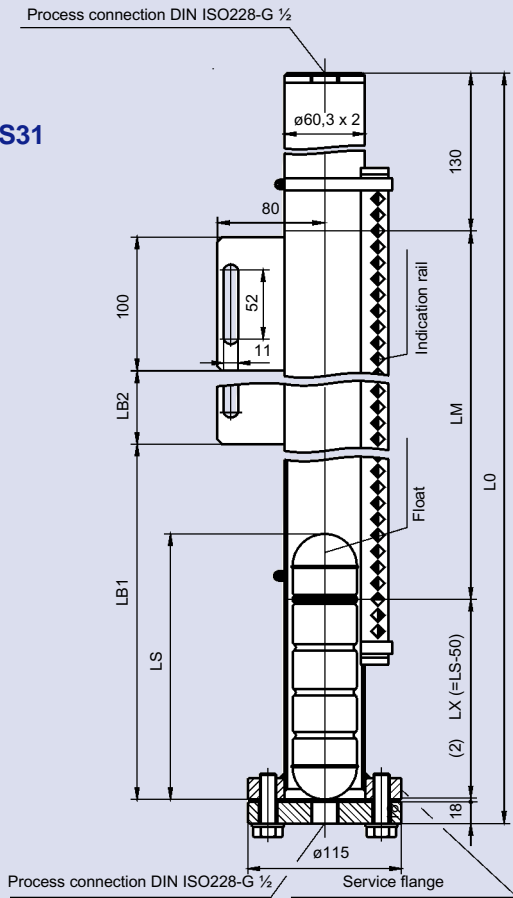

## BNA-S32

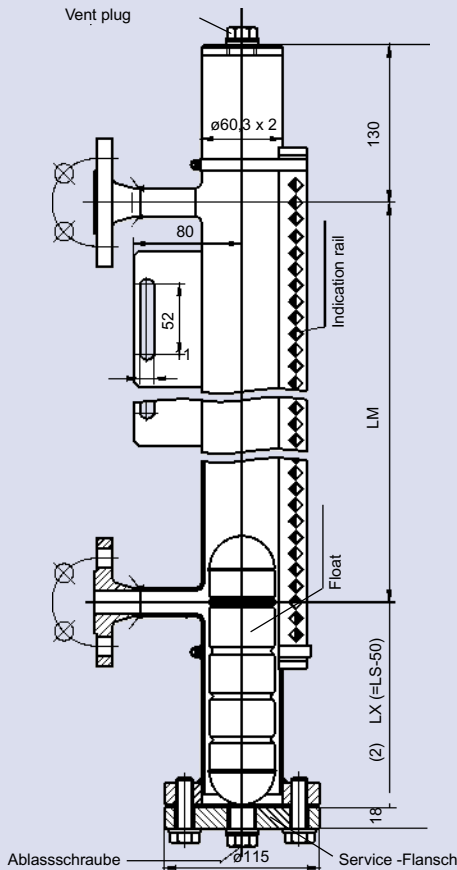

### Technical Data

#### Standard Version:

Measuring range: L0 max. 6000 mm in one piece, max. LM in split sections on request

Bypass tube: Stainless Steel No. 1.4571 (SS 316 Ti)  
PN 16, diameter 60,3 x 2 mm

Proof pressure: 1,5 x max. operating pressure

Process conn.: G 1/2 top and bottom with plug

Side connections: Threaded R 1/2, R 3/4, 1" or  
DIN flanges DN 15, 25, 32, 40 oder 50, or  
ASA DN 1/2", 3/4", 1", 1 1/4", 1 1/2"

Indication rail: Makrolon (Polycarbonate) with red and white  
square flags for medium temp. up to 150 °C

Float(s): Standard PN 25: VA 50/10 in 1.4571,  
min. density: 0,62 g/cm<sup>3</sup>, max. temp. 150 °C

**Type:** Top G 1/2, bottom service-flange:  
**BNA-S31**, top and bottom connections G 1/2  
**BNA-S32**, side connections

#### Options:

Indication rail: Aluminum, black anodized,  
square flags painted silver/red,  
up to max. 350 °C –A2

Float(s): **VA 50/15** in 1.4571, with M4 plug,  
min. density: 0,63 g/cm<sup>3</sup>, max. temp.: 150 °C

**TT 50/10** in Titanium,  
min. density: 0,56 g/cm<sup>3</sup>, max. temp.: 320 °C

**TT 50/15** in Titanium, with M4 plug,  
min. density: 0,57 g/cm<sup>3</sup>, max. temp. 320 °C

Connections: Instead of G 1/2 top and bottom, 1/2" NPT,  
or flange connections with  
weld neck flanges

#### Accessories:

- Limit switches
- Analog output
- Scale
- Isolation
- Tests / Certificates

# BNA-S35/-S36

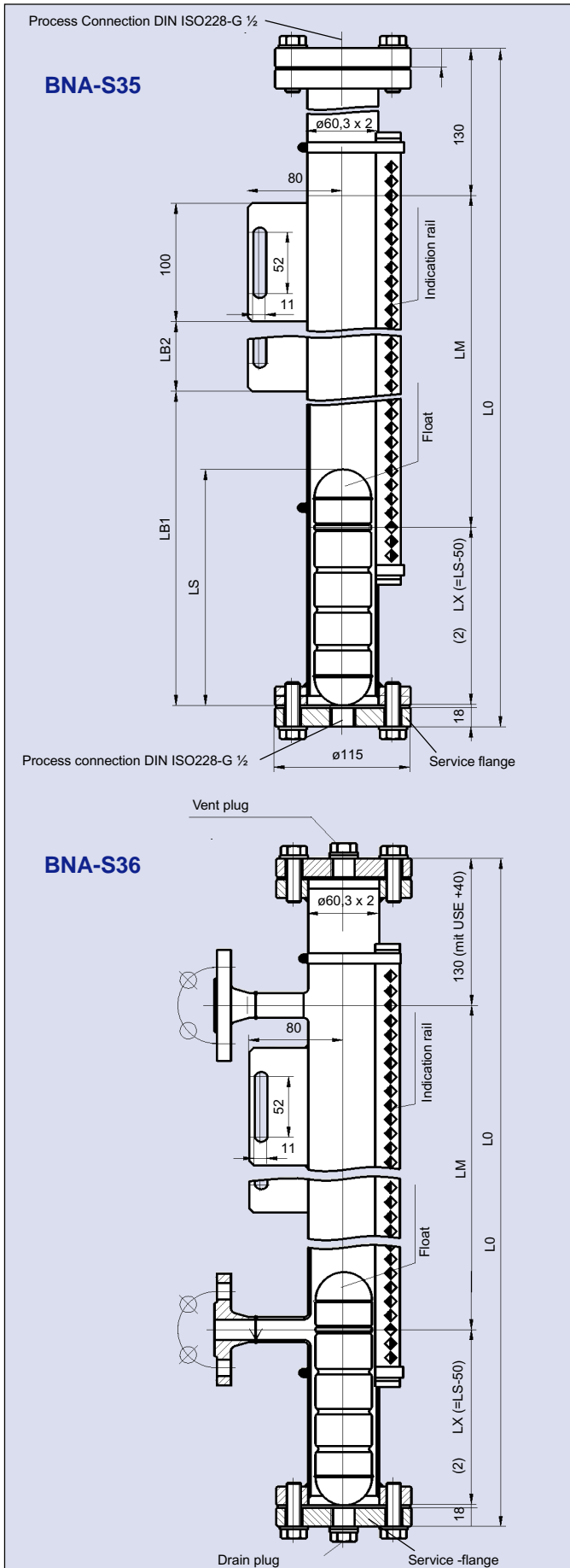

## Technical Data

### Standard Version:

Measuring range: L0 max. 6000 mm in one piece, max. LM in split sections on request

Bypass tube: Stainless Steel No. 1.4571 (SS 316 Ti)  
PN 16, diameter 60,3 x 2 mm

Proof pressure: 1,5 x max. operating pressure

Process conn.: G 1/2 top and bottom with plug

Side connections: Threaded R 1/2, R 3/4, 1" or  
DIN flanges DN 15, 25, 32, 40 oder 50, or  
ASA DN 1/2", 3/4", 1", 1 1/4", 1 1/2"

Indication rail: Makrolon (Polycarbonate) with red and white  
square flags for medium temp. up to 150 °C

Float(s): VA 50/10 in 1.4571,  
min. density: 0,62 g/cm<sup>3</sup>, max. temp. 150 °C

Type: Top and bottom service-flanges:  
**BNA-S35**, top and bottom connections G 1/2  
**BNA-S36**, side connections

### Options:

Indication rail: Aluminum, black anodized,  
square flags painted silver/red,  
up to max. 350 °C –A2

Float(s): **VA 50/15** in 1.4571, with M4 plug,  
min. density: 0,63 g/cm<sup>3</sup>, max. temp.: 150 °C

**TT 50/10** in Titanium,  
min. density: 0,56 g/cm<sup>3</sup>, max. temp.: 320 °C

**TT 50/15** in Titanium, with M4 plug,  
min. density: 0,57 g/cm<sup>3</sup>, max. temp. 320 °C

Connections: Instead of G 1/2 top and bottom, 1/2" NPT,  
or flange connections with  
weld neck flanges

### Accessories:

- Limit switches
- Analog output
- Scale
- Isolation
- Tests / Certificates

09 / 02 BNA-ENG 02/1

Barksdale Bypass Level Indicators

Specifications are subject to changes without notice.

# BNA-S41/-S42

09 / 02 BNA-ENG 02/1

Barksdale Bypass Level Indicators

Specifications are subject to changes without notice.

## BNA-S41

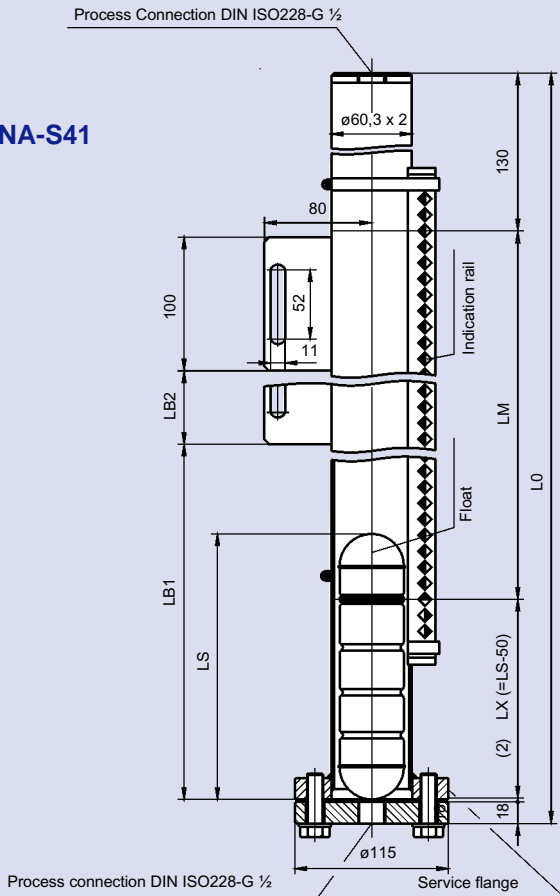

## BNA-S42

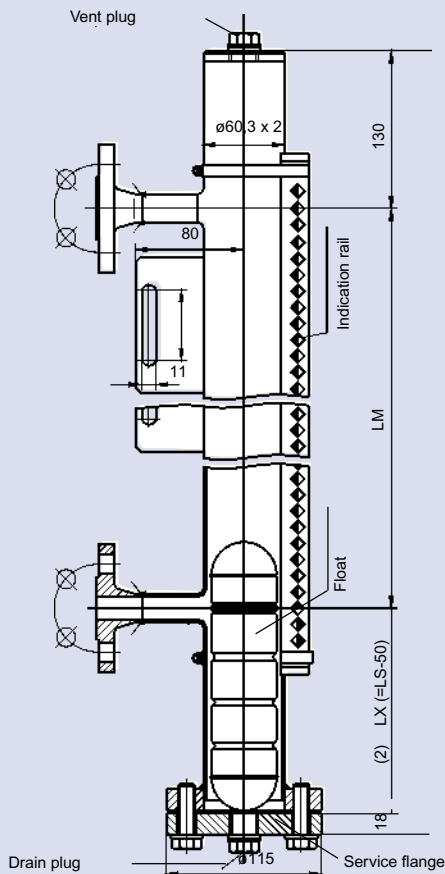

## Technical Data

### Standard Standard version:

- Measuring range: L0 max. 6000 mm in one piece, max. LM in split sections on request
- Bypass tube: Stainless Steel No. 1.4571 (SS 316 Ti) PN 40, diameter 60,3 x 2 mm
- Proof pressure: 1,5 x max. operating pressure
- Process conn.: G 1/2 top and bottom with plug
- Side connections: Threaded R 1/2, R 3/4, 1" or DIN flanges DN 15, 25, 32, 40 or 50, or ASA DN 1/2", 3/4", 1", 1 1/4", 1 1/2"
- Indication rail: Makrolon (Polycarbonate) with red and white square flags for medium temp. up to 150 °C
- Float(s): Standard PN 40: TT 50/10 in Titanium, min. density: 0,56 g/cm<sup>3</sup>, max. temp.: 320 °C
- Type: Top G 1/2, bottom service-flange:  
**BNA-S41**, top and bottom connections G 1/2  
**BNA-S42**, side connections

### Options:

- Indication rail: Aluminum, black anodized, square flags painted silver/red, up to max. 350 °C –A2
- Float(s): **TT 50/10** in Titanium, min. density: 0,57 g/cm<sup>3</sup>, max. temp.: 320 °C
- Connections: Instead of G 1/2 top and bottom, 1/2" NPT, or flange connections with weld neck flanges

### Accessories:

- Limit switches
- Analog output
- Scale
- Isolation
- Tests / Certificates

# BNA-S45/-S46

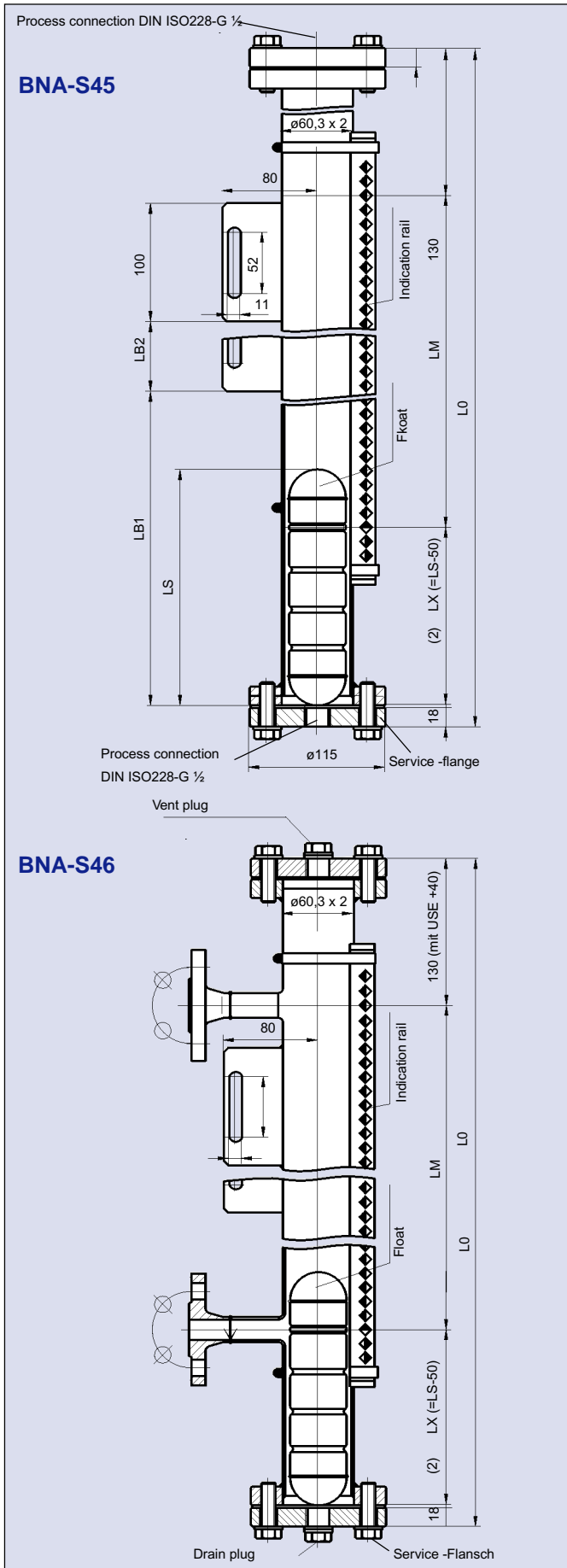

## Technical Data

### Standard version:

Measuring range: L0 max. 6000 mm in one piece, max. LM in split sections on request

Bypass tube: Stainless Steel No. 1.4571 (SS 316 Ti)  
PN 40, diameter 60,3 x 2 mm

Proof pressure: 1,5 x max. operating pressure

Process conn.: G 1/2 top and bottom with plug

Side connections: Threaded R 1/2, R 3/4, 1" or  
DIN flanges DN 15, 25, 32, 40 or 50,  
or ASA DN 1/2", 3/4", 1", 1 1/4", 1 1/2"

Indication rail: Makrolon (Polycarbonate) with red and white square flags for medium temp. up to 150 °C

Float(s): Standard PN 40: TT 50/10 in Titanium,  
min. density: 0,62 g/cm<sup>3</sup>, max. temp.: 320 °C

**Type:** Top G 1/2, bottom service-flange:  
**BNA-S45**, top and bottom connections G 1/2  
**BNA-S46**, side connections

### Options:

Indication rail: Aluminum, black anodized,  
square flags painted silver/red,  
up to max. 350 °C –A2

Float(s): **TT 50/15** in Titanium, with plug M4  
min. density: 0,57 g/cm<sup>3</sup>, max. temp.: 320 °C

Connections: Instead of G 1/2 top and bottom, 1/2" NPT,  
or flange connections with  
weld neck flanges

### Accessories:

Limit switches  
Analog output  
Scale  
Isolation  
Tests / Certificates

# BNA-S51/-S52

09 / 02 BNA-ENG 02/1

Barksdale Bypass Level Indicators

Specifications are subject to changes without notice.

## BNA-S51

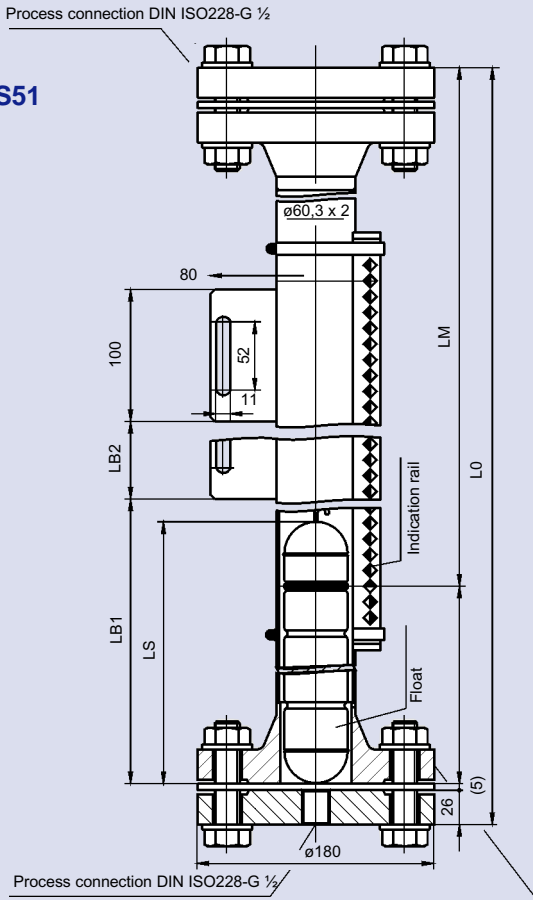

## BNA-S52

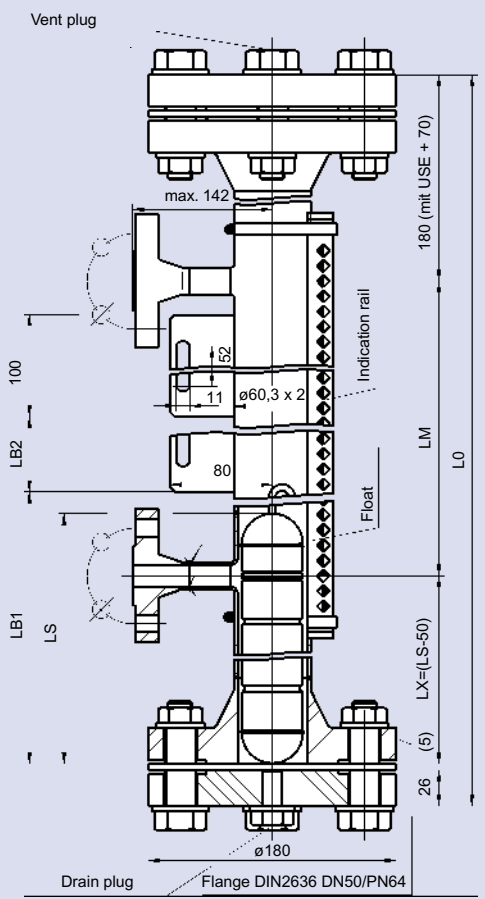

### Technical Data

#### Standard Version:

Measuring range: L0 max. 6000 mm in one piece, max. LM in split sections on request  
 Bypass tube: Stainless Steel No. 1.4571 (SS 316 Ti)  
 PN 64, diameter 60,3 x 2 mm

Proof pressure: 1,5 x max. operating pressure

Process conn.: G 1/2 top and bottom with plug

Side connections: Flanges in: DIN flanges DN 15, 25, 32, 40 or 50, or ASA DN 1/2", 3/4", 1", 1 1/4", 1 1/2"

Indication rail: Makrolon (Polycarbonate) with red and white square flags for medium temp. up to 150 °C

Float(s): Standard: VA 50/20-VAE (ventilated) in 1.4571, min. density: 0,65 g/cm³, max. temp.: 150 °C

Type: Top G 1/2, bottom service-flange:  
**BNA-S51**, top and bottom connections G 1/2  
**BNA-S52**, side connections

#### Options:

Indication rail: Aluminum, black anodized, square flags painted silver/red, up to max. 350 °C –A2

Float(s): **TT 50/20** in Titanium, min. density: 0,57 g/cm³, max. temp.: 320 °C

Connections: Instead of G 1/2 top and bottom, 1/2" NPT, or flange connections with weld neck flanges

#### Accessories:

- Limit switches
- Analog output
- Scale
- Isolation
- Tests / Certificates

# BNA-U101/-U102

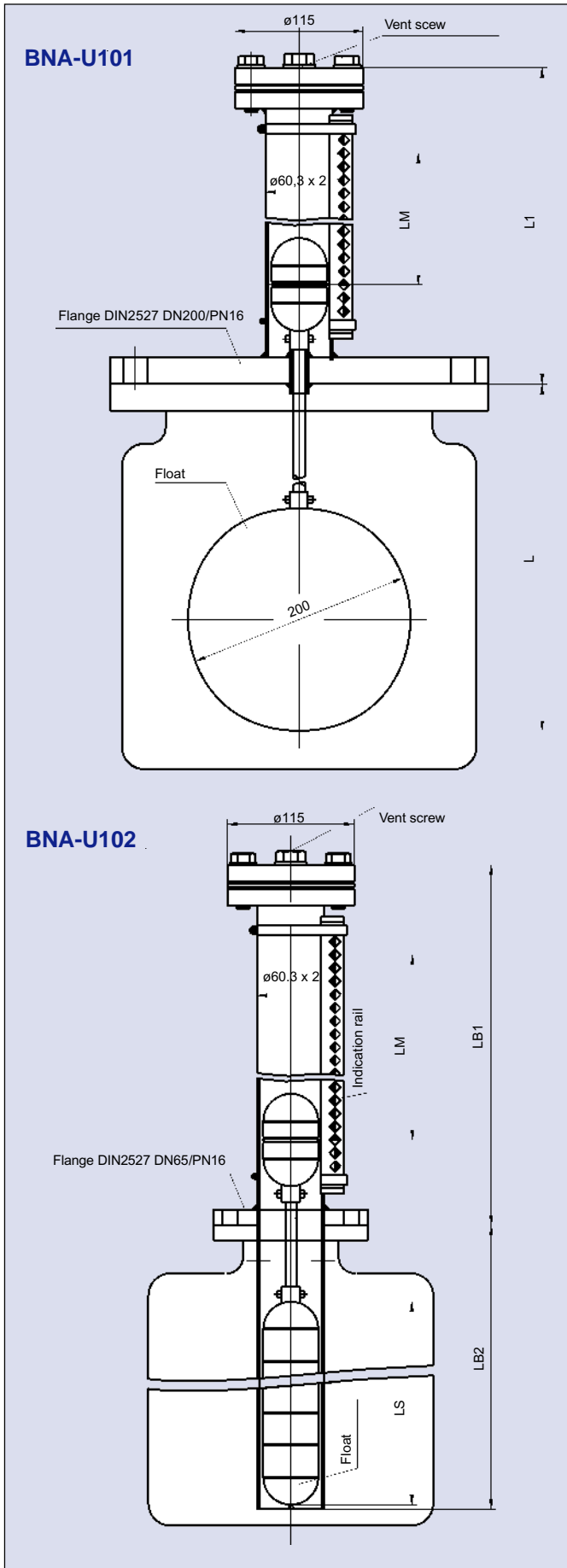

## Technical Data

### Standard Version:

Measuring range: Depends on the buoyancy of the float (which again depends on the density of the medium (g)), max. LM on request

Bypass tube: Stainless Steel No. 1.4571 (SS 316 Ti)  
PN 16, diameter 60,3 x 2 mm

Proof pressure: 1,5 x max. operating pressure

Indication rail: Makrolon (Polycarbonate) with red and white square flags for medium temp. up to 150 °C

Dimensions: L1 = L+200 mm, L1 depends on LM, geometry of the tank and density of medium

**Type:**  
**BNA-U101,**  
with VA flange DIN 2527 DN 200 / PN 16  
Float: VA200 with VA tube 12 x 1  
LM max. 6000 mm , 5300 mm /  $\gamma = 0,6 \text{ g/cm}^3$

**BNA-U102,**  
with VA flange DIN 2527 DN 65 / PN 16  
Float: VA 50-400 with ABS tube  
LM max. 4500 mm /  $\gamma 1.0$

Float : TT 50-400 with ABS tube  
LM max. : 7000 mm /  $\gamma 1.0 \text{ g/cm}^3$   
: 5000 mm /  $\gamma 0,8 \text{ g/cm}^3$

### Options:

Float(s): more floats on request

Connections: Special- (bigger) flange connections or U102 in split versions are possible (to simplify transportation and installation).

### Accessories:

Limit switches  
Scale  
Trip amplifier  
Isolation  
Tests / Certificates

### Order data:

Type: BNA-U101 or BNA-U102 with float type  
Medium: Density of medium in  $\text{g / cm}^3$   
Measuring length: LM in mm  
Installation data: Distance from max. filling level to bottom of flange, further details or drawings with installation geometry are helpful

Options and accessories: On request

# BNA-U301 / -U401 / -U701

## Technical Data

### Standard Version:

09 / 02 BNA-ENG 02/1

Measuring range: Depends on the buoyancy of the float (which again depends on the density of the medium (g)), e. g.:

Float:	LM in mm	min. dens. in g / cm <sup>3</sup>
PVC 300	1000	0,7
PVC 400	2000	0,8
PP 300	4000	0,8
PP 400	4000	0,67

Bypass tube: Diameter 63,3 x 2 mm

Nominal pressure/ Max. temp.:

PVC:	2,5 bar, max. temp. 60 °C
PP:	2,5 bar, max. temp. 80 °C
PVDF:	6 bar, max temp. 140 °C

Proof pressure: 1,5 x max. operating pressure

Connection: Flange DN 65

Indication rail: Makrolon (Polycarbonate) with red and white square flags for medium temp. up to 150 °C

Dimensions: L1 = L+200 mm, L1 depends on LM, geometry of the tank and density of medium

**Type:**  
**BNA-U301-PVC,**  
**BNA-U401-PVDF,**  
**BNA-U701-PP**

### Options:

Float(s): more floats on request

Connections: Special- (bigger) flange connections or U102 in split versions are possible (to simplify transportation and installation)

**Accessories:**  
 Limit switches  
 Scale  
 Trip amplifier  
 Isolation  
 Tests / Certificates

### Order data:

Type: BNA U301, BNA 401 or BNA701  
 Medium: Density of medium in g/cm<sup>3</sup>  
 Measuring length: LM in mm  
 Installation data: Distance from max. filling level to bottom of flange, further details or drawings with installation geometry are helpful

Options and accessories: On request

Specifications are subject to changes without notice.

**BNA-U301**  
**BNA-U401**  
**BNA-U701**

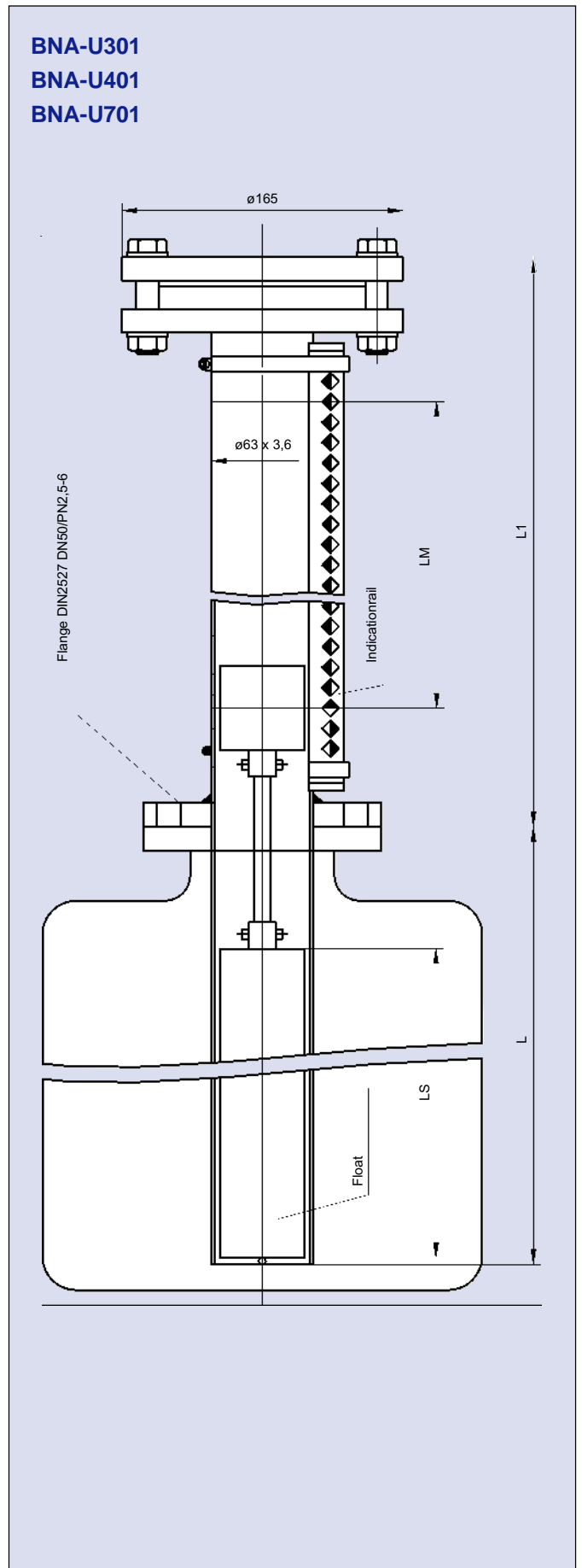

**BNA-K301 / -K401 / -K701**  
**BNA-K302.0 / -K402.0 / -K702.0**

**BNA-K301 / -K401 / -K701**

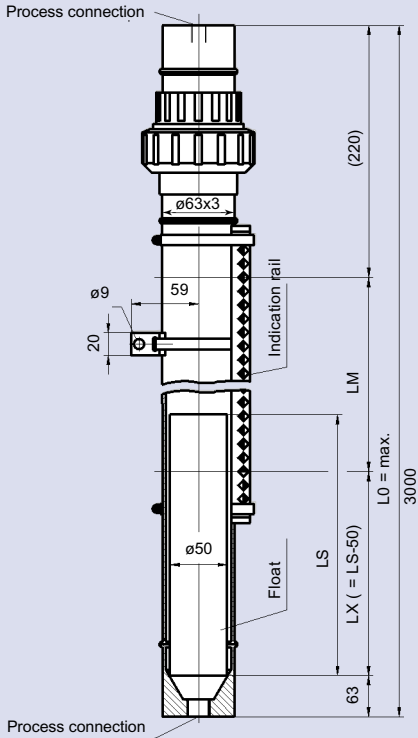

**BNA-K302.0 / -K402.0 / -K702.0**

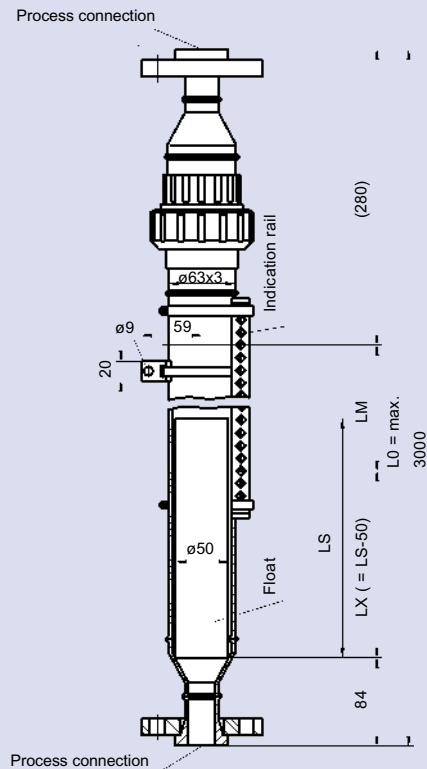

**Technical Data**

**Standard Version:**

Measuring range: L0 max. 3000 mm in one piece, in split sections on request

Bypass tube: Diameter 63,3 x 2 mm

Nominal pressure/ PVC: 2,5 bar, max. temp. 60 °C  
 Max. temp.: PVDF: 6 bar, max temp. 140 °C  
 PP: 2,5 bar, max. temp. 80 °C

Proof pressure: 1,5 x max. operating pressure,

Process conn.: G ½, G 1 top and bottom, lap joint flanges with stub ends DN 15 up to DN 32

Indication rail: Makrolon (Polycarbonate) with red and white square flags for medium temp. up to 150 °C

**Type:**

**BNA-K301-PVC**, with connection thread,  
**BNA-K302.0-PVC**, with flanges,  
 Float PVC 50/10,  $\gamma$  min. 0,54 g/cm<sup>3</sup>

**BNA-K401-PVDF**, with connection thread,  
**BNA-K402.0-PVDF**, with flanges,  
 Float PVDF 50/10,  $\gamma$  min. 0,66 g/cm<sup>3</sup>

**BNA-K701-PP**, with connection thread,  
**BNA-K702.0-PP**, with flanges,  
 Float PP 50/10,  $\gamma$  min. 0,45 g/cm<sup>3</sup>

The standard floats are relatively light. They are, however, weighted when manufactured and monitor the exact level.

**Notice:** Please indicate medium density in your order

**Options:**

Connections: Special threads, glued or welded joints on request

**Accessories:**

- Limit switches
- Scale
- Trip amplifier
- Isolation
- Tests / Certificates

**BNA-K302.1 / -K402.1 / -K702.1**  
**BNA-K303 / -K403 / -K703**

**Technical Data**

**Standard Version:**

Measuring range: L0 max. 3000 mm in one piece, in split sections LM on request

Bypass tube: Diameter 63 x 2 mm

Nominal pressure/ Max. temp.:  
 PVC: 2,5 bar, max. temp. 60 °C  
 PVDF: 6 bar, max temp. 140 °C  
 PP: 2,5 bar, max. temp. 80 °C

Proof pressure: 1,5 x max. operating pressure

Process conn.: Lap joint flanges with stub ends and flange adaptors acc. to DIN 8063/PN 10:  
 top and bottom: DN 50 (all types with ...02.1)  
 side: DN 15 to DN 50 (all types with ...03)

Indication rail: Makrolon (Polycarbonate) with red and white square flags for medium temp. up to 150 °C

Float(s): Standard version: length 200 mm  
 Min. density of medium: PVC 0,54 g/cm<sup>3</sup>  
 PVDF 0,66 g/cm<sup>3</sup>  
 PP 0,45 g/cm<sup>3</sup>

The standard floats are relatively light. They are, however, weighted when manufactured and monitor the exact level.  
**Notice:** Please indicate medium density in your order

**Type:** Process connections DN 50 top and bottom:  
**BNA-K302.1 PVC**  
**BNA-K402.1 PVDF**  
**BNA-K702.1 PP**

Side connections:  
**BNA-K303 PVC**  
**BNA-K403 PVDF**  
**BNA-K703 PP**

**Options:**

Connections: Special flange connections are possible

**Accessories:**

Limit switches  
 Scale  
 Trip amplifier  
 Isolation  
 Tests / Certificates

09 / 02 BNA-ENG 02/1

Barksdale Bypass Level Indicators

Specifications are subject to changes without notice.

**BNA-K302.1 / -K402.1 / -K702.1**

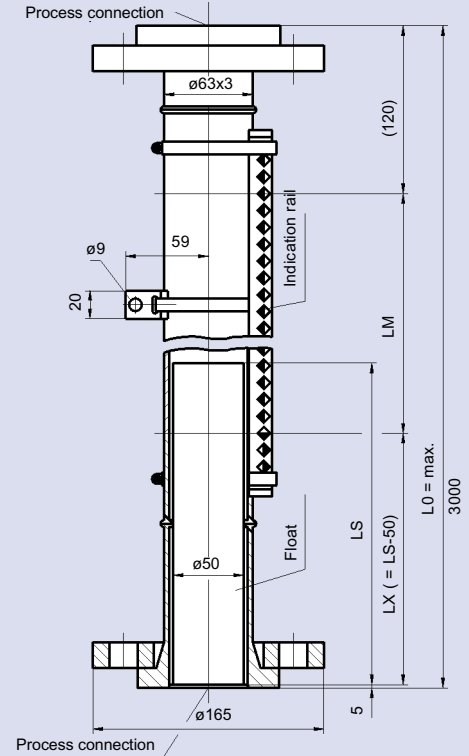

**BNA-K303 / -K403 / -K703**

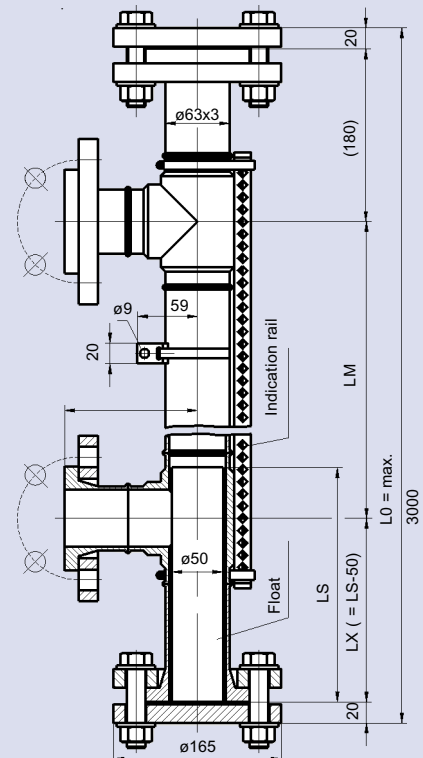

# Limit Switches GK 01/GK 01L/GK 02/GK HT1

## GK-Housing

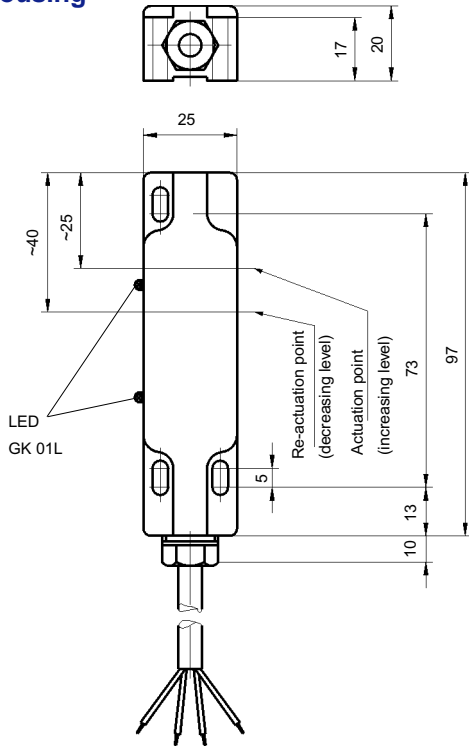

## GK 02

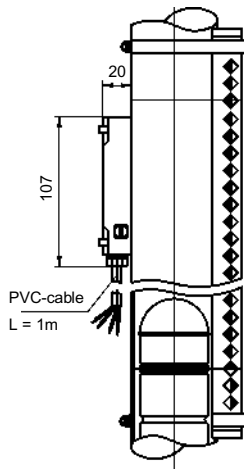

## GK HT1

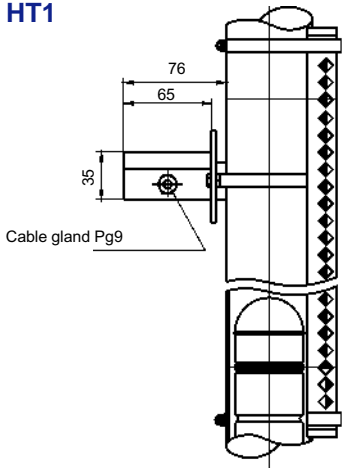

## Description

Apart from the GK HT1 which has a microswitch, all other limit switches have bi-stable reed contacts. As the float rises with the liquid level the magnet system will switch-over the contact. This contact status will remain until the float passes again and the switch status returns to its original position. During installation the contact status can be set with a ring magnet or the float. The limit switches are designed for quick and easy installation; only a screw driver is needed to tighten the stainless steel clamps. They can be mounted in any position around the bypass tube, however the cable direction should preferably be downward.

The switch hysteresis depends on the position of the switch on the bypass tube and is smallest when the switches are installed closely along the indication rail.

## Technical Data:

**GK 01** Limit switch  
 Housing: Aluminum, completely potted  
 Cable: Silicone isolation, 4 x 1,5 mm<sup>2</sup>, length 1 m, other lengths on request  
 Protection class: IP65  
 Contact rating: 220 V AC / 1 A / 60 VA, 220 V DC / 1 A / 40 W  
 Temperature limits: -55 °C...140 °C

**GK 01L** Limit switch with red and green LED indicating the switch over status  
 Housing: Aluminum, completely potted  
 Cable: PVC isolation, 5 x 0,5 mm<sup>2</sup>, length 1 m, other lengths on request  
 Protection class: IP65  
 Contact rating: 24 V DC / 1A / 40 W  
 Temperature limits: -25 °C...80 °C

**GK 02** EEx d Limit switch; PTB No Ex-82/1085  
 Housing: Aluminum, completely potted  
 Cable: PVC isolation, 4 x 0,5 mm<sup>2</sup>, length 1 m, other lengths or versions on request  
 Protection class: IP65 and EEx d IIC T6  
 Contact rating: 220 V AC / 0,6 A / 30 VA, 220 V DC / 0,4 A / 20 W  
 Temperature limits: -25 °C...75 °C

**GK HT1** Limit switch for high temp. with SPDT switch  
 Housing: Aluminum 65 x 65 x 40 mm, PG9 cable gland  
 Protection class: IP65  
 Contact rating: 220 V AC / 1 A / 80 VA  
 Temperature limits: -55 °C...350 °C

When larger contact ratings are needed as the reed contacts allow, (60 VA and 30 VA for EEx)relays must be used.

When frequent changing process requirements make a permanent contact position difficult to handle we recommend to order our trip amplifier UAS 3 with 4...20 mA output, which enables set point changes by touching a key pad and many additional features.

## Floats

The newly designed floats have less weight, are therefore shorter than the earlier versions and we have reduced our stock to the versions listed below. The type .../15 is designed to simply match the indication for fluids with higher densities by adding weight in the float through the M4 plug.

The required total weight of the float is calculated with the formula:

$$283 \times \gamma \text{ (Density) of the medium} = \text{weight in g}$$

The .../20 types are vented floats with automatic condensers (VAE) and designed for pressures over 40 bar.

Type	Float material	Length in mm LS	P max in bar	T max in °C	Wght. in g	Volum. in cm <sup>3</sup>	$\gamma$ min ** in g/cm <sup>3</sup>	Extras
VA 50/10	1.4571	200	25	150	205	360	0,62	---
VA 50/15	1.4571	200	25	150	207	360	0,63	with M4 plug
VA 50/20	1.4571	200	VAE	150		360	0,65	with VAE tube
TT 50/10	Titanium	200	40	320	186	360	0,56	---
TT 50/15	Titanium	200	40	320	191	360	0,57	with M4 plug
TT 50/20	Titanium	200	VAE	320		360	0,60	with VAE tube
VA 30/02	1.4571	200	25	150	104	141	0,85	only BNA-S21/S22
TT 30/02	Titanium	200	25	150	102	141	0,85	only BNA-S21/S22
TT 30/03	Titanium	200	40	320	103	141	0,86	only BNA-S21/S22
BN 32/100	Buna N	100	10	90	48	80	0,62	oil up to 110 °C (only BNA-S21/S22)
PVC 50/10	PVC	200	2,5	60	205	393	0,54	give fluid density*
PP 50/10	PP	200	2,5	80	175	393	0,45	give fluid density*
PVDF 50/10	PVDF	200	6	140	253	393	0,66	give fluid density*

\* The plastic floats are now, with the new magnet system, very light and will be weight-corrected at all times. Please enter the fluid density of the medium in your order.

\*\* Minimum advised medium density based upon 175 mm (or 87.5%) immersion of the float. The ideal immersion depth of the 200-floats is 150 mm, but an immersion depth of 175 mm is absolutely sufficient for most of the applications. Only in very viscous or dirty media a "last-buoyancy" of 25 mm only is not recommended.

For very light media like some hydrocarbons we offer special floats please consult factory.

### Maximum Pressures

Higher temperatures will reduce the maximum pressure the system might be exposed to. According to DIN 2413 are these pressure limits (in bar) for our SS tubes, material No 1.4571 (SS316Ti) as follows:

Outer diameter in mm	Wall thickness in mm	20 °C	100 °C	150 °C	200 °C	250 °C	300 °C	350 °C	400 °C
		bar	bar	bar	bar	bar	bar	bar	bar
60,3	2,00	83	70	64	58	54	52	49	46
60,3	2,77	115	87	90	81	76	71	68	65
60,3	2,90	121	101	94	85	79	75	71	68

For the bypass systems in engineered plastics we have the following pressure limits (in bar):

Medium temperat.	-40 °C	-20 °C	0 °C	20 °C	40 °C	60 °C	80 °C	100 °C	120 °C	100 °C
max. pressure	bar	bar	bar	bar	bar	bar	bar	bar	bar	bar
PVDF	10	10	10	10	10	8,6	6,5	4,6	3	2
PP	---	10	10	10	8,2	5	2,5	0,7	---	---
PVC	---	---	6	6	6	1	---	---	---	---

# Continuous Level Indicating Transmitters XM, XMi

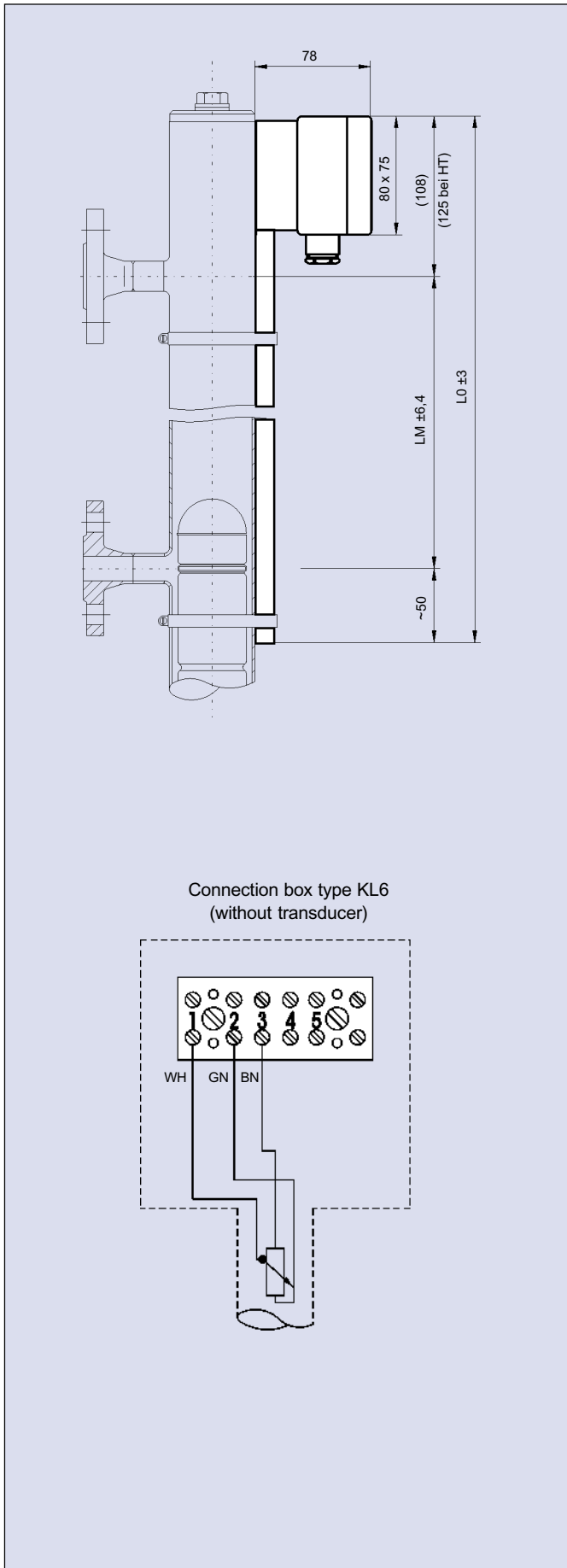

## Description

The measuring principle is a network of magnetically activated reed switches with resistors arranged inside a vertical tube. The flux field transmitted by the float causes reed switches to operate in a „2-3-2 at a time“ sequence, rendering an effective reading of 6,4 mm accuracy and a repeatability of ±1 mm and provide a reed switch and signal redundancy.

The network is fitted in a 13 Ø mm stainless steel tubing and is connected to the bypass tube with SS clamps, an electrical connection box houses the electrical terminals or a signal conditioner. This design enables also retrofitting on existing bypass tubes.

The XM and XMi are designed as simple potentiometers, the intrinsically safe version XMi is approved acc. ATEX CENELEC.

## Standard versions

- XM** with potentiometer output. Max. resistance 10 kOhm.
- Temperature limits: -10...90 °C, or -50...150 °C for the high temperature version
- Tubing: Material No 1.4571 (SS 316Ti), Ø 13 mm,
- Total length (L0) is indication length (LM) + 158 mm, however LM +175 mm for the high temp. version up to 150 °C
- Connection box: KLS, in Aluminum, 75 x 80 x 50 mm, and screw terminals, protection class IP65
- Ind. Length (LM): same length as the indication rail, as spare part order please give LM

### Order number example XM- / XT-:

#### XM-HT-R12-LM2500

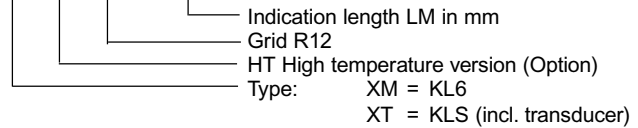

### XM<sub>i</sub>, like XM but with external ground screws and blue cable gland.

- Temperature limits: T1...T4 to 100 °C, T5 to 65 °C, T6 to 50 °C
- Total length (L0) is indication length (LM) + 158 mm, however LM +175 mm for the high temp. version up to 150 °C
- L0 max is 6000 mm

**Attention:** Intrinsic safety is only applicable with an approved current / power limiting device (Ui: 24 V DC). Total length (L0) max. 6000 mm acc. approval.

### Order number example XM<sub>i</sub>- / XT<sub>i</sub>- (Ex-model):

#### XM<sub>i</sub>-R12-LM2500

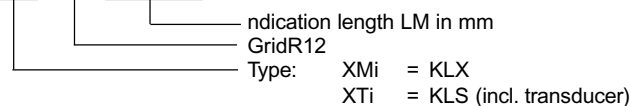

# Continuous Level Indicating Transmitters XT, XT<sub>i</sub>

09 / 02 BNA-ENG 02/1

## Connection Scheme

### Level sensor with transmitter - Non-Ex-application

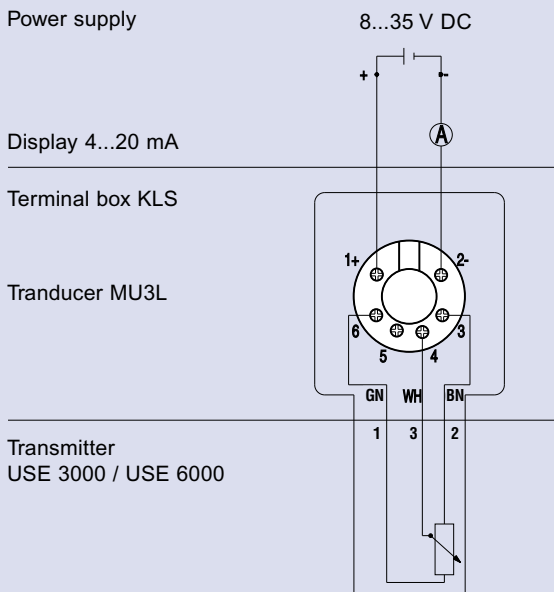

## Description

The measuring principle is the same as the XM series however the XT series has signal conditioners built into the connection box.

These signal conditioners convert the resistance ( potentiometer) network into a two wire 4...20 mA signal. For interface measurement the output can easily be inverted 20...4mA. As option there is also a version with signal linearisation in 7 sections or 60 points.

Two versions are available:

- XT Standard
- XT<sub>i</sub> EExi Intrinsically safe for hazardous areas.

All are completely potted CE proofed and appropriate for rough industry applications.

### XT Standard version

Transmitter with type MU3L: Circuit monitoring and selective output (Namur NE 43) 3,5 mA or 23 mA in case of a failure. Protection against wiring failure and short circuit.

Barksdale Bypass Level Indicators

### Level Sensor with Transmitter - Ex-application

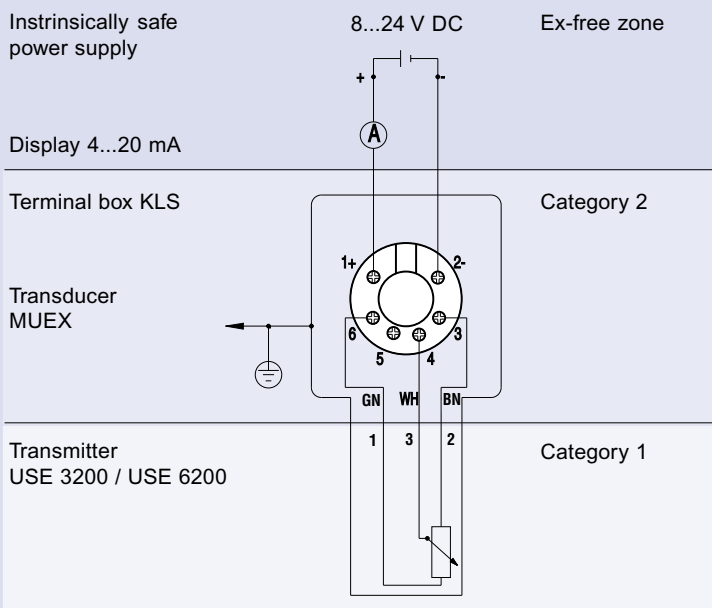

Supply power: 8...35 VDC, max. 10% rest ripple

Output: 4...20 mA, reversed polarity protected

Load: max. 700 Ohm at 24 V

Temperature limits: -40...85 °C

Response time: 0,33 sec

Accuracy: max. ±0,2% f. s.

### XT<sub>i</sub> Intrinsically safe version

Transmitter with type MUEX, intrinsically safe with ATEX-approval EExia IIC T1...T6, reversed polarity protected and circuit monitoring and selective output (Namur NE 43) 3,5 mA or 23 mA.

Supply power: 8...24 VDC, max. 10% rest ripple

Output: 4...20 mA, reversed polarity protected

Load: max. 700 Ohm at 24 V

Temperature limits: T1...T4: -40...85 °C

T5 and T6: -40...60 °C

Response time: 0,33 sec

Accuracy: max. ±0,2% f. s.

Specifications are subject to changes without notice.

## Dimensions (in mm)

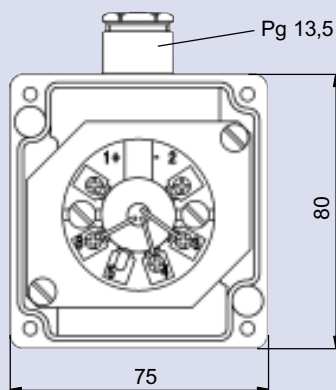

If not ordered different the standard configuration of the selective output is set at ≤3,5 mA.

# Trip Amplifier and Indicating Instrument Type UAS3

**Trip amplifier for external sensors (pressure, temperature, level, etc.), digital display, 4 switching outputs and 1 analog output, accuracy class 0,2% f. s.**

## Features

8-digit 14-segment LCD display with bargraph and trend indication, microprocessor-controlled, self monitoring, all parameters are configured by keypad, units selectable, high accuracy, selective keypad lock, quick scanning rate (1 ms)

**Display Range** (free scalable): -9999...+9999

## Applications

OEM-applications, hydraulics and pneumatics, test beds, heavy industry

## Technical Data

Measuring Principle	: Amplifier with 12 Bit A/D-converter
Materials :	
Housing (Electronics)	: Aluminum cast G AL SI 12
Seal (Housing)	: Neoprene
Keypad	: Polyester foil
Operating Elements	: Keypad with easy response pushbuttons
Protection Class	: IP65
Dimensions	: 100 (W) x 135 (H) x 80 (D) mm
Weight	: appr. 1080 g
Analog Inputs	
Current Input	: 4... 20 mA
Voltage Input	: 0...10 V DC
Resistance Input	: 0,5...100 kOhm
Temperature	: PT100 element acc. to IEC751, please see UTS 3
Linearity Error	: <math>\pm 0,2\%</math> f. s. at 25 °C
A/D-Converter:	
Resolution	: 12 bit (4096 steps per measuring span)
Scanning Rate	: 1000/s (for peak value memory)
Operating Display	: 8-digit 14-segment LCD display, height 12 mm, red
Bargraph	: 24-Segment for actual value
Trend Arrows	: last changes
Display Range	: -9999...+9999 (scalable)
Display Rate	: 4/s
Display Unit	: All technical units
Electrical Connection:	
Sensor Connection	: Plug 3-pin according to DIN 43650 incl. electrical plug
Cable Gland	: Plug-in, terminal strip with 14 screws for 1,5 mm <sup>2</sup> , AWG14 slots 1 x PG 13,5 side entry = standard 2 x PG 13,5 top entry = optional



Temperature Influence	: <math>\pm 0,01\%</math> f. s. / 10K
Compensation Range	: -10 °C... +70 °C
Repeatability	: <math>\pm 0,01\%</math> f. s.
Temperature Range	: -10 °C...+ 70 °C (Electronics) -30 °C...+ 80 °C (Storage)
Power Supply	: 18... 30 V DC unregulated, max. 10 % residual ripple, reversed polarity protected
Power Consumption	: appr. 350 mA at $U_b = 24$ V DC (without load)
Analog Output	
Current Output	: 4... 20 mA
Load	: max. $RI = (U_b - 12 \text{ V}) / 20 \text{ mA}$ $RI = 600 \text{ Ohm}$ at $U_b = 24 \text{ V DC}$
Load Influence	: 0,3% / 100 Ohm
Scanning Rate	: 1 ms
Voltage Output	: 0...10 V DC
Rating	: max. 10 mA, short circuit-proof
Adjustment Range	: 25%...100% f. s.
4 x Relay Output(s) - SPDT-Contacts	
Contact Rating	: max. 120 V DC / 250 V AC max. 120 W / 1250 VA
Cycles	: 1 Mio. at 24 V DC / 2 A
Switching Rate	: max. 20/s
Delay	: 16 ms... 9,9 s adjustable
Operation Time	: 1 ms
Status Display	: S1 ... S4 on LCD display
Options	: Mounting bracket, shock mounts

09 / 02 BNA-ENG 02/1

Barksdale Bypass Level Indicators

Specifications are subject to changes without notice.

# Trip Amplifier and Indicating Instrument Type UAS3

## Dimensions (in mm)

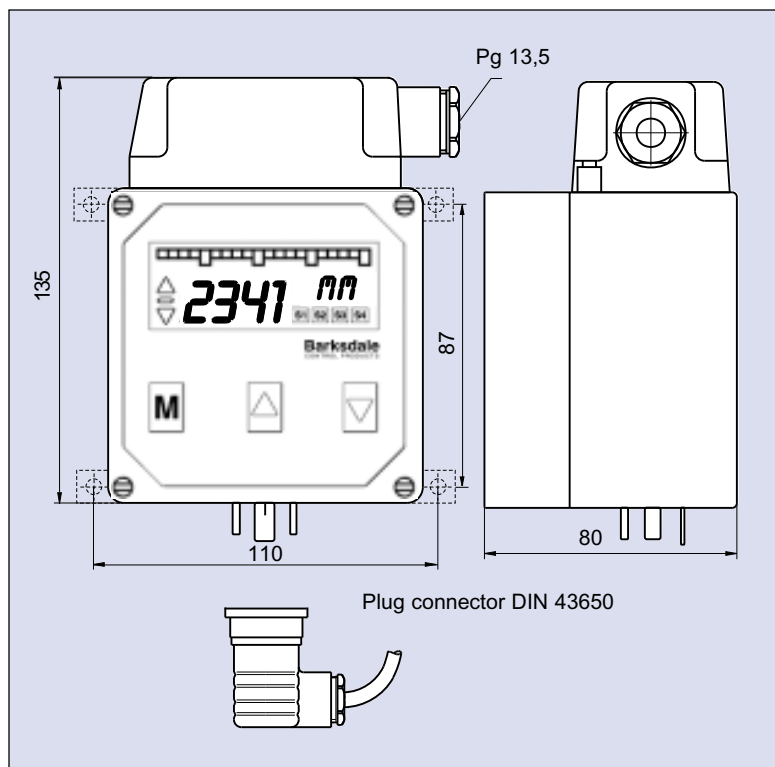

## Electrical connection

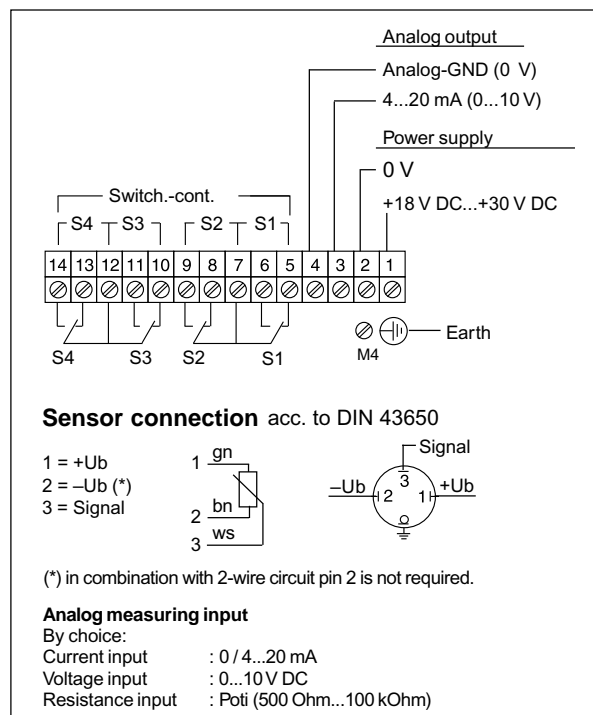

## Order numbers

Electronic trip amplifier with 4 relays, 1 input and digital display		
Analog input	Analog output	Order number
4 ... 20 mA	---	0003-026
4 ... 20 mA	4 ... 20 mA	0003-024
4 ... 20 mA	0 ... 10 V	0003-025
0 ... 10 V	---	0003-032
0 ... 10 V	4 ... 20 mA	0003-030
0 ... 10 V	0 ... 10 V	0003-031
resistance 0,5 ... 100 kOhm	---	0003-029
resistance 0,5 ... 100 kOhm	4 ... 20 mA	0003-027
resistance 0,5 ... 100 kOhm	0 ... 10 V	0003-028

## Accessories

Order number	Description
0099-001	Mounting brackets for wall-mounted housing (1 set = 2 pcs.)

# Accessories

### Calibrated scales

**SK:**

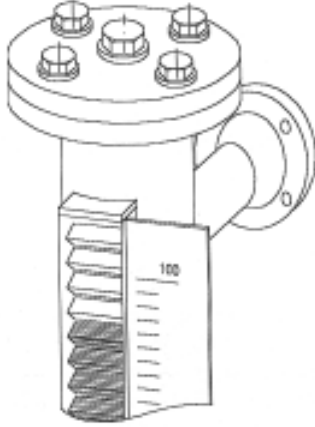

To quantify the visual indication provided by the rotary flag assembly, a calibrated scale can be attached to the indication rail. The scales are available in various designs, in black ink on silver background up to 150 °C, or engraved in aluminum with filled-in red or black painted markings for higher temperatures.

Any unit of measure can be inscribed; we just need following data:

- units of measure,
- scale start and end values,
- LM (Indication length)
- scale marking in cm, dm, inch, etc.
- any special requests, like non linear scale markings, size of markings, special materials...etc

### Isolation

**PO:** For outdoor or applications where moisture or dust can be expected we recommend the use of our protective shrink tubing for the indication rail. Temperature limits: -55...135 °C.

**AR:** Armaflex Isolation: For installations where energy must be saved or the media can have temperatures lower than the ambient and condensation or a build-up of ice must be avoided we suggest this isolation of foam rubber. Temperature limits -40...105 °C.

**GL:** Glass Isolation: For personnel protection against skin burning when the media is over 60 °C, we offer a woven glass isolation around the tube, Temperature limits -40...500°C.

Other isolations like mineral fibers with aluminum cover - also in combination with electrical heating - can be supplied upon request.

### Heating and double wall design

**EL:** Electrical trace heating: Tape type heating cable can be supplied with thermostat control to maintain temperatures between -30...65 °C. Nominal voltage 230 VAC.

**ELX:** Electrical heating for hazardous areas: Special type heating cable with EEx approvals, can be supplied with EEx thermostat control to maintain temperatures between -30...65 °C. Nominal voltage 230 VAC.

**D:** Double tube: When locally available steam or hot / cold water could be the right media to keep the bypass tube at the required temperature. For these applications we offer another tube welded over the bypass chamber. Process connections for this utility medium are threaded R½ or R¾, or flanged DN 15 or DN 25 on the back or on the side of this double tube. The total length L0 can increase minimal depending on the process connections.

### Tests and certificates

- X-ray transmission test of welding seams
- Pressure test with certificates
- Certificates of compliance according to DIN 50049-2.1, 50049-2.2, or 50049-3.1b
- TÜV verification
- Special test certificates

Detailed information on all accessories on request.

## Order data BNA-S21/-S22

## Bypass Level Indicator

## Type:

BNA-S21 PN 25, G $\frac{1}{2}$  female process connections top and bottom, Makrolon indication rail  
 BNA-S22 PN 25, side mounted process connections, Makrolon indication rail

## Side connections:

R  $\frac{1}{2}$ " female threads  
 $\frac{1}{2}$ " NPT female threads  
 DN 15 flanges according to DIN 2635 (flange faces Form C)  
 DN 20 flanges according to DIN 2635 (flange faces Form C)  
 DN 25 flanges according to DIN 2635 (flange faces Form C) OD tube remains 21,3 mm outer  $\varnothing$   
 DN  $\frac{1}{2}$ " flanges according to ANSI B 16,5 300 lbs  
 DN  $\frac{3}{4}$ " flanges according to ANSI B 16,5 300 lbs  
 DN 1" flanges according to ANSI B 16,5 300 lbs, OD tube remains 21,3 mm outer  $\varnothing$

## Indicator length in mm:

2000/1 (example): LM = 2000 mm / in one piece  
 3600/2 (example): LM = 3600 mm / in two pieces

## Float(s):

VA 30/10 material 1.4571, max. 25 bar / 150 °C, min. density: 0,85 g/cm $^3$   
 TT 30/02 material Titanium, max. 40 bar / 150 °C, min. density: 0,85 g/cm $^3$   
 BN 32/100 material Buna N, max. 10 bar / 90 °C, min. density: 0,62 g/cm $^3$

## Indication rail:

MA Makrolon = Standard, max. T 150 °C

## Isolation: (AR and PO are also together available)

AR Armaflex, foam rubber isolation, temp. limits: -40...105 °C  
 GL protective cover; glass fiber tape, temp. limits: -40...500 °C  
 PO Polyolefin shrink tubing; weather and dirt protection

## Limit switch:

(Please note: The first digit indicates the quantity)  
 1GK01 one limit switch GK01, temp. limits: -55...140 °C  
 1GK01L as above, with red and green LED  
 1GK02 one limit switch EX, Temp. limits: -25...75 °C

## Analog output:

XM potentiometer resistive output  
 XM<sub>i</sub> as above with EEx i approval  
 XT with signal cond. 4...20 mA  
 XT<sub>i</sub> with 4...20 mA output EEx<sub>i</sub>

## Trace heating:

EL El. trace heating  
 ELX El. trace heating with EEx d spec.

Detailed specification  
 needed in order to  
 process orders

09 / 02 BNA-ENG 02/1

Barksdale Bypass Level Indicators

Specifications are subject to changes without notice.

BNA-S22- DN15- 2600/1-VA 30/10-MA-AR- 2GK01L- XT<sub>i</sub>- EL (Example)

## Order data BNA-S31 to BNA-S46

<b>Type:</b>	Version:
BNA-S31	PN 16, top and bottom G ½ process conn., , service-flange only bottom
BNA-S32	PN 16, side conn., indication rail Makrolon, service-flange only bottom
BNA-S35	PN 16, top and bottom G ½ process conn., indication rail Makrolon, service-flange top and bottom
BNA-S36	PN 16, side conn., indication rail Makrolon, service-flange top and bottom
BNA-S41	PN 40, top and bottom G ½ process conn., indication rail Makrolon, service-flange only bottom
BNA-S42	PN 40, side conn., indication rail Makrolon, service-flange only bottom
BNA-S45	PN 40, top and bottom G ½ process conn., indication rail Makrolon, service-flange top and bottom
BNA-S46	PN 40, side conn., indication rail Makrolon, service-flange only bottom

**Side connections:**

- R ½" or ½" NPT female threads
- R ¾" or ¾" NPT female threads
- R 1" or 1" NPT female threads
- DN 15 flange PN16 / DIN 2633 or PN 40 / DIN 2635
- DN 20 flange PN16 / DIN 2633 or PN 40 / DIN 2635
- DN 25 flange PN16 / DIN 2633 or PN 40 / DIN 2635
- DN 32 flange PN16 / DIN 2633 or PN 40 / DIN 2635
- DN 40 flange, as above, with concentric reducer from DN 40 to DN 32
- DN 50 flange, as above, with concentric reducer from DN 50 to DN 32
- DN ½" flange PN 16 / 150 lbs, PN 40 / 300 lbs ANSI B 16,5
- DN ¾" flange PN 16 / 150 lbs, PN 40 / 300 lbs ANSI B 16,5
- DN 1" flange PN 16 / 150 lbs, PN 40 / 300 lbs ANSI B 16,5
- DN 1¼" flange PN 16 / 150 lbs, PN 40 / 300 lbs ANSI B 16,5
- DN 1½" flange, as above, with concentric reducer from DN 32 to DN 40
- DN 2" flange, as above, with concentric reducer from DN 32 to DN 50

**Dimensions in mm (Examples):**

- 2000/1 LM = 2000 mm / in one piece
- 3600/2 LM = 3600 mm / in two pieces

**Float:**

- VA 50/10 material: 1.4571, max. 25 bar / 150 °C, min. density: 0,62 g/cm³
- VA 50/15 material: 1.4571, as above, with plug M4
- TT 50/10 material: Titanium, max. 40 bar / 320 °C, min. density: 0,56 g/cm³
- TT 50/15 material: Titanium, as above, with plug M4

**Indication rail:**

- MA Makrolon = standard, max. temp.: 150 °C
- A2 Aluminum painted, max. temp.: 350 °C

**Isolation:**

- AR Armaflex, foam rubber isolation, temp. limits: -40...105 °C
- GL protective cover; glass fiber tape, temp. limits: -40...500 °C
- PO Polyolefin shrink tubing; weather and dirt protection

**Limit switch:** (Please note: The first digit indicates the quantity)

- 1GK01 one limit switch GK01, temp. limits: -55...140 °C
- 1GK01L as above, with red and green LED.
- 1GK02 one limit switch EX, temp. limits: -25...75 °C
- 2GKHT1 two limit switches high temperature, temp.: -55...350 °C

**Analog output:**

- XM potentiometer resistive output
- XMi as above with EEx i approval
- XT with signal cond. 4...20 mA
- XTi with 4...20 mA output EExi

**Scale**

- SK scale

**Heating:**

- EL electr. trace heating
- ELX in EEx d
- D double tube

Detailed specification needed in order to process orders

BNA-S32- DN25- 2600/1- VA 50/15- MA- AR- 2GK01- XTi- SK- EL (Example)

# Order data BNA-S51/-S52

**Type:** Version:  
 BNA-S51 PN 64, top and bottom G ½ process conn. in DIN2527, blind flange DN 65 top + bottom, indication rail Makrolon  
 BNA-S52 PN 64, side/side connections, service-flanges DIN2527, blind flange DN 65 top + bottom, indication rail Makrolon

**Side connections:**

- DN 15 flange DIN 2637
- DN 20 flange DIN 2637
- DN 25 flange DIN 2637
- DN 32 flange DIN 2637
- DN 40 flange DIN 2637, with concentric reducer from DN 40 to DN 32
- DN 50 flange DIN 2636, with concentric reducer from DN 50 to DN 32
- DN ½" flange 600 lbs ANSI 16,5
- DN ¾" flange 600 lbs ANSI 16,5
- DN 1" flange 600 lbs ANSI 16,5
- DN 1¼" flange 600 lbs ANSI 16,5
- DN 1½" flange 600 lbs ANSI 16,5, with concentric reducer from DN 40 to DN 32
- DN 2" flange 600 lbs ANSI 16,5, with concentric reducer from DN 50 to DN 32

**Dimensions in mm (Examples):**

- 2000/1 LM = 2000 mm / in one piece
- 3600/2 LM = 3600 mm / in two pieces

**Float:** vented with condensate tube (VAE)

- VA 50/20 material: 1.4571, max. 25 bar / 150 °C, min. density: 0,65 g/cm³
- TT 50/20 material: Titanium, max. 40 bar / 320 °C, min. density: 0,60 g/cm³

**Indication rail:**

- MA Makrolon = standard, max. temp.: 150 °C
- A2 Aluminum painted, max. temp.: 350 °C

**Isolation:**

- AR Armaflex, foam rubber isolation, temp. limits: -40...105 °C
- GL protective cover; glass fiber tape, temp. limits: -40...500 °C
- PO Poliolefin shrink tubing; weather and dirt protection

**Limit switch:** (Please note: The first digit indicates the quantity)

- 1GK01 one limit switch GK01, temp. limits: -55...140 °C
- 1GK01L as above, with red and green LED.
- 1GK02 one limit switch EX, temp. limits: -25...75 °C
- 2GKHT1 two limit switches high temperature, temp.: -55...350 °C

**Analog output:**

- XM potentiometer resistive output
- XMi as above with EEx i approval
- XT with signal cond. 4...20 mA
- XTi with 4...20 mA output EExi

**Scale**

- SK scale

**Heating:**

- EL electr. trace heating
- ELX in EEx d
- D double tube

Detailed specification needed in order to process orders

BNA-S52- DN25- 2600/1-VA 50/20- MA- AR- 2GK01- XTi- SK- EL (Example)

09 / 02 BNA-ENG 02/1

Barksdale Bypass Level Indicators

Specifications are subject to changes without notice.

# Order data BNA-K301 / -K401 / -K701

# BNA-K302.0 / -K402.0 / -K702.0

- Type:** Version:  
 BNA-K301 PVC top and bottom threaded process connection, indication rail Makrolon, service port bottom only  
 BNA-K302.0 PVC top and bottom flanged process connection, indication rail Makrolon, service port bottom only  
 BNA-K401 PVDF top and bottom threaded process connection, indication rail Makrolon, service port bottom only  
 BNA-K402.0 PVDF top and bottom flanged process connection, indication rail Makrolon, service port bottom only  
 BNA-K 701 PP top and bottom threaded process connection, indication rail Makrolon, service port bottom only  
 BNA-K 702.0 PP top and bottom flanged process connection, indication rail Makrolon, service port bottom only

**Thread connections:**

- G 1/2 female threads
- G 3/4 female threads
- G 1 female threads
- DN 15 flange PN16 / DIN 2633 or PN 40 / DIN 2635
- DN 20 flange PN16 / DIN 2633 or PN 40 / DIN 2635
- DN 25 flange PN16 / DIN 2633 or PN 40 / DIN 2635
- DN 32 flange PN16 / DIN 2633 or PN 40 / DIN 2635
  
- DN 1/2" flange PN 16 / 150 lbs, PN 40 / 300 lbs ANSI B 16,5
- DN 3/4" flange PN 16 / 150 lbs, PN 40 / 300 lbs ANSI B 16,5
- DN 1" flange PN 16 / 150 lbs, PN 40 / 300 lbs ANSI B 16,5
- DN 1 1/4" flange PN 16 / 150 lbs, PN 40 / 300 lbs ANSI B 16,5

**Dimensions in mm (Examples):**

- 2000/1 LM = 2000 mm / in one piece
- 3600/2 LM = 3600 mm / in two pieces

**Float:**

- PVC 50/10 max. 2,5 bar / 60 °C, min. density: 0,54 g/cm<sup>3</sup>
  - PP 50/10 max. 2,5 bar / 80 °C, min. density: 0,45 g/cm<sup>3</sup>
  - PVDF 50/10 max. 6,0 bar / 140 °C, min. density: 0,66 g/cm<sup>3</sup>
- When ordering, please specify density of the medium and we will calibrate the float accordingly

**Isolation:**

- AR Armaflex, foam rubber isolation, temp. limits: -40...105 °C
- PO Poliolefin shrink tubing; weather and dirt protection

**Limit switch:** (Please note: The first digit indicates the quantity)

- 1GK01 one limit switch GK01, temp. limits: -55...140 °C
- 1GK01L as above, with red and green LED.
- 1GK02 one limit switch EX, temp. limits: -25...75 °C

**Analog output:**

- XM potentiometer resistive output
- XMi as above with EEx i approval
- XT with signal cond. 4...20 mA
- XTi with 4...20 mA output EExi

**Scale:**

- SK scale

**Heating:**

- EL el. trace heating
- ELX in EEx d

Detailed specification needed in order to process orders

BNA-K 701-DN25-2600/1-PP 50/10 PO- 2GK01-XTi- SK- EL (Example)

Order data BNA-K302.1 / -K402.1 / -K702.1

BNA-K303 / -K403 / -K703

09 / 02 BNA-ENG 02/1

Barksdale Bypass Level Indicators

Specifications are subject to changes without notice.

<b>Type:</b>	Version:
BNA-K302.1	PVC top and bottom lap joint flange. DIN 8063 PN10 DN50
BNA-K303	PVC side / side lap joint flanges DN 50, service-flanges top and bottom
BNA-K402.1	PVDF top and bottom lap joint flange. DIN 8063 PN10 DN50
BNA-K403	PVDF side / side lap joint flanges DN 50, service-flanges top and bottom
BNA-K702.1	PP top and bottom lap joint flange. DIN 8063 PN10 DN50
BNA-K703	PP side / side lap joint flanges DN 50, service-flanges top and bottom

**Side connections:**

DN 15	flange, lap joint with stub end acc. PN10 / DIN 8063, reduced from DN 50 T-piece
DN 20	flange, lap joint with stub end acc. PN10 / DIN 8063, reduced from DN 50 T-piece
DN 25	flange, lap joint with stub end acc. PN10 / DIN 8063, reduced from DN 50 T-piece
DN 32	flange, lap joint with stub end acc. PN10 / DIN 8063, reduced from DN 50 T-piece
DN 40	flange, lap joint with stub end acc. PN10 / DIN 8063, reduced from DN 50 T-piece
DN 50	flange, lap joint with stub end acc. PN10 / DIN 8063
DN 1/2"	flange, lap joint with stub end acc. PN10 / DIN 8063, reduced from DN 50 T-piece
DN 3/4"	flange, lap joint with stub end acc. PN10 / DIN 8063, reduced from DN 50 T-piece
DN 1"	flange, lap joint with stub end acc. PN10 / DIN 8063, reduced from DN 50 T-piece
DN 1 1/4"	flange, lap joint with stub end acc. PN10 / DIN 8063, reduced from DN 50 T-piece
DN 1 1/2"	flange, lap joint with stub end acc. PN10 / DIN 8063, reduced from DN 50 T-piece
DN 2"	flange, lap joint with stub end acc. PN10 / DIN 8063

**Dimensions in mm (Examples):**

2000/1 LM = 2000 mm / in one piece  
 3600/2 LM = 3600 mm / in two pieces

**Float**

PVC 50/10	max. 2,5 bar / 60 °C, min. density: 0,54 g/cm <sup>3</sup>
PP 50/10	max. 2,5 bar / 80 °C, min. density: 0,45 g/cm <sup>3</sup>
PVDF 50/10	max. 6,0 bar / 140 °C, min. density: 0,66 g/cm <sup>3</sup>

When ordering, please specify density of the medium and we will calibrate the float accordingly.

**Isolation:**

AR	Armaflex, foam rubber isolation, temp. limits: -40...105 °C
PO	Poliolefin shrink tubing; weather and dirt protection

**Limit switch:** (Please note: The first digit indicates the quantity)

1GK01	one limit switch GK01, temp. limits: -55...140 °C
1GK01L	as above however with red and green LED.
1GK02	one limit switch EX, temp. limits: -25...75 °C

**Analog output:**

XM	potentiometer resistive output
XM <sub>i</sub>	as above with EEx i approval
XT	with signal cond. 4...20 mA
XT <sub>i</sub>	with 4...20 mA output EExi

**Scale:**

SK	scale
----	-------

**Heating:**

EL	el. trace heating
ELX	in EEx d

Detailed specification needed in order to process orders

BNA-K703- DN50- 2600/1-PP 50/10 AR- 2GK01- XT- SK- EL (Example)

**The fastest way to more information:**

... just complete the order form below and fax it!

**Fax to :** **Barksdale GmbH**  
 Dorn-Assenheimer Strasse 27  
 D-61203 Reichelsheim / Germany  
**Fax: +49 (0) 60 35 - 9 49-111**

**From :** Name : .....  
 Company : .....  
 Department : .....  
 Street / P.O.Box : .....  
 Post Code / City : .....  
 Telephone : .....  
 Fax : .....  
 e-mail : .....  
**Date :** .....

Please send me detailed information about:

- Mechanical Pressure Switches
- Electronic Pressure Sensors
- Electronic Pressure Switches
- Level Switches
- Continuous Tank Level Indicating Systems
- Level Probes
- Bypass Level Indicating Systems
- Flow Switches
- Mechanical Temperature Switches
- Electronic Temperature Sensors
- Electronic Temperature Switches
- Shear Seal- / Air Suspension Valves

Please send me the Barksdale product CD with all available information about the complete product range (format: PDF).

In addition to the Bypass Level Indicators listed in this catalog our product range includes various other instrumentation and control equipment to monitor, measure and control

 **Pressure**

 **Temperature**

 **Level**

 **Flow**

We have the right solution for your measuring tasks.

Just contact us.



# Our Products



05 / 03 BNA-EN 03/1

Barksdale Bypass Level Indicators

Specifications are subject to changes without notice.

Represented by:



**Barksdale GmbH**  
Dorn-Assenheimer Strasse 27  
D-61203 Reichelsheim / Germany

Tel.: +49 - 60 35 - 9 49-0  
Fax: +49 - 60 35 - 9 49-111 and 9 49-113  
e-mail: [Info@Barksdale.de](mailto:Info@Barksdale.de)  
Web-Site: <http://www.barksdale.de>

Art.-Nr. 923-0870